



**SANiTEC**

Professional cleaning solutions

Product catalogue





# Pure power

## Pure power for cleaning professionals

Sanitec is Italtchimica's line dedicated to professional detergents and cosmetics, where the precision of science meets the excellence of performance.

Every Sanitec product is developed from Italtchimica research and is studied in its laboratories to guarantee maximum performance, safety of use and respect for the environment.

The complete range of solutions covers the needs of the Ho.Re.Ca, industry, facility management, professional laundromats and medical facilities, offering consistent and measurable results in every application.

# Index

## **Sanitec and Italchimica 6**

Areas of application	<b>6</b>
Italchimica	<b>8</b>
Sanitec	<b>10</b>
Sustainability	<b>12</b>

## **Kitchen 15**

Mechanical dishwashing	<b>21</b>
Trilogy concentrated system	<b>27</b>
Descalers	<b>30</b>
Hand dishwashing	<b>31</b>
Disinfectants	<b>33</b>
Degreasers and surface cleaners	<b>36</b>

## **Floors 45**

Odour neutralizing detergents	<b>50</b>
Detergents	<b>52</b>
Disinfectants	<b>58</b>
Other surfaces	<b>60</b>

## **Multi-surface 63**

Bathroom and toilet	<b>66</b>
Glass and dusting	<b>74</b>
Disinfectants	<b>76</b>
Other surfaces	<b>78</b>
Concentrated Dosy system	<b>80</b>
Kit	<b>84</b>
Accessories	<b>87</b>

## **Air fresheners 89**

Floors and hard surfaces	<b>92</b>
Rooms	<b>94</b>
Rooms and fabrics	<b>96</b>

## **Laundry 99**

Automatic dosing	<b>107</b>
L-Brain Connect and accessories	<b>112</b>
Hand dosing	<b>114</b>
Pretreatment	<b>118</b>



## **Skin care** **121**

Hand cleansers	<b>123</b>
Body cleansers	<b>130</b>
Body creams	<b>132</b>

## **Stone and metal surfaces** **135**

PETRA 24®	<b>139</b>
Detergents	<b>140</b>
Additives	<b>143</b>

## **Industry** **147**

Detergents	<b>148</b>
Hand cleansers	<b>150</b>

## **Swimming pool** **153**

Swimming pool water treatment	<b>154</b>
-------------------------------	------------

## **Ecolabel** **159**

Ecolabel-certified products	<b>161</b>
Green Power kit	<b>167</b>

## **Disinfectants** **169**

Italian certified disinfectant products	<b>171</b>
Disinfection kit	<b>177</b>

Alphabetical index	<b>178</b>
Product code index	<b>180</b>
Icons and certifications	<b>182</b>

# Areas of application

The Sanitec range consists of specific lines designed for a variety of professional uses. Sanitec meets all the needs of cleaning companies, the Ho.Re.Ca. sector, industry, laundry, care and medical facilities.

Its versatility also extends to the cleaning of swimming pools, to the treatment of monuments of historical and artistic value, to specific skin care ranges.

## Kitchen

- Effective, surface-friendly detergents
- Full suitability for H.A.C.C.P. control plans



## Floors and other surfaces

- Detergents for difficult surfaces, suitable for all application areas
- Highly concentrated products without the need for PPE at the dosage of use
- Room and fabric fragrances



## Laundry

- Super-concentrated formulas: up to 3 times more than standard products
- Ecolabel certified system



## Skin care

- Products specifically developed for healthcare applications
- Gentle formulas for effective cleansing and care of all skin types



## Stone and metal surfaces

- Removal of sulfation stains and blackened crusts caused by pollution
- A line that preserves the characteristics of the stone, environmentally friendly and safe for the user



# Italchimica

## Science, technology and industrial reliability

Italchimica, owner of the Sanitec brand, is one of Italy's leading industrial players in the design, formulation and production of highly specialised detergents and cosmetics. With a strictly science-driven approach, it develops professional solutions that improve people's quality of life, with a constant focus on process efficiency and the protection of natural resources and the environment.

The in-house integration of research and development, production and quality control enables Italchimica to guarantee high standards, complete traceability and measurable performance at every stage of the production cycle. The laboratories, equipped with advanced analytical technologies, work according to scientific protocols that ensure stable, effective and safe formulations for the user and the environment.



Thanks to a modern industrial structure in Padua of 30,000 square metres, a logistics hub of over 20,000, 10 production lines and an organisation geared to continuous collaboration with the customer, Italchimica offers quick answers and customised solutions to professionals in the Ho.Re.Ca, industry, facility management, professional laundry and the medical sector.



Our  
**Vision**

Italchimica creates innovative and sustainable cleaning and cosmetics products for people's quality of life and the care of the planet.

Our  
**Mission**

Italchimica is the landmark industrial operator in Italy in the creation, production and marketing of detergent and cosmetic formulas that contribute to improving people's quality of life, while respecting natural resources, quickly and proactively serving both the professional and consumer markets.

Italchimica's reliable service and organisation in constant dialogue with the customer provides quick answers and anticipates its customers' needs.

## Our values



### Rapidity

We work with innovative drive, rigour and professionalism to provide quick answers to our customers, partners and the community



### Transparency

We transparently communicate our M.O., our formulas and claims, our development goals



### Creation

We are curious and open to change, we can create great things.  
We are characterised by professionalism, technicality and innovative spirit, to progress and innovate, always and with great adaptability



# Sanitec, from the experience of Italchimica

Sanitec was developed from innovative research and an efficient and certified industrial system. It is now a benchmark for cleaning professionals in Italy and in more than 60 countries worldwide. A unique combination of power, technology and reliability.

Research & Development is at the heart of Italchimica, owner of the Sanitec brand, an integrated system where chemistry, technology, marketing and sustainability work in synergy to generate high-performance solutions for professional detergents and cosmetics. Each project stems from listening to the market and analysing the real needs of professionals and end users, transforming operational requirements into rigorous formulation protocols.

## A scientific method geared towards the care of natural resources

Italchimica's R&D approach focuses on the environment and natural resources. Research activities are guided by criteria of responsibility and traceability, favouring renewable and biodegradable raw materials, ingredients that are locally available as much as possible, and solutions formulated to reduce environmental impact throughout the product life cycle.

From feasibility studies to the choice of raw materials, from benchmark analyses to continuous formulation updates, every step responds to a clear principle: to develop effective, safe and sustainable products with scientifically verified claims.

Qualified teams in various scientific and technical disciplines carry out the following activities:

- **New business development**
- **Current business**
- **Quality control**
- **Regulatory**

# Numbers

## that prove the efficiency of the research

Italchimica's R&D structure operates with an advanced industrial model, supported by laboratories equipped with advanced analytical technologies. Key data on scientific activity:

# 50K

Laboratory tests performed each year

# 400

Active and continuously developing formulations

# 40

PMC products

Italian certification for disinfectant products

# 57

Ecolabel products

## Certifications

Italchimica's products for home and personal care, as well as for the hygiene and disinfection of professional and domestic spaces, from the *hôtellerie* to health and medical facilities and catering, are certified and comply with safety standards.

Italchimica's priority is to ensure regulatory compliance and maintain high quality standards over time, through strict controls and continuous verification of claims.

### Product certifications



### System certifications



Management system for Gender Equality

**Green  
Change  
Matters**



# Sustainability as an industrial choice

Green Change Matters is Italmichica's sustainability journey based on measurable data, scientific accountability and continuous improvement. A concrete approach that integrates sustainability, innovation and performance, transforming chemistry into a driver of value for people, the environment and the markets that the company operates in.

Every year, Italmichica reports its results through the Sustainability Report, based on an ISO 14064-certified system for measuring emissions and environmental impacts. A process that ensures transparency, reliability and constant monitoring of progress to support increasingly informed industrial decisions.



Using the QR code, you can access the latest sustainability report and the leaflet that highlights the most important aspects, in addition to the archive of previous reports.

## Water resources

We favour concentrated formulas, optimise water management to limit packaging and transport impacts



## Raw materials

We select easily biodegradable materials to help protect the environment



ISO 14064 certification  
For the measurement of greenhouse gas emissions



# Measuring to improve

As part of its ESG journey, Italmichica has obtained ISO 14064-1:2018 certification, the international standard that defines criteria for quantifying, monitoring and reporting greenhouse gas (GHG) emissions consistent with UN climate frameworks.

The adoption of this system allows the company to have a structured and verified inventory of its carbon footprint, accurately identifying the main emission sources along the entire value chain, including direct and indirect emissions related to energy, transport and raw materials.

The certification represents an operational environmental management tool: the data collected directs concrete and measurable improvement plans, which include logistics and intermodal optimisation, palletisation efficiency, the development of recyclable packaging and waste recovery systems, the reuse of industrial water and the increase of formulations with biodegradable surfactants.

This system is based on globally recognised metrics, allowing Italmichica to monitor its environmental performance over time and integrate sustainability into its production processes in a structured and continuous manner.

<h2>Packaging</h2> <p>We favour the selection of recycled, recovered and process-recyclable components</p>  	<h2>Rifiuti</h2> <p>We are committed to identifying opportunities to generate value at the end-of-life of materials through their recovery and recycling</p>  
<h2>Emissioni</h2> <p>We invest in clean energy with a CO<sub>2</sub> reduction and offsetting plan</p>   	<h2>Energy resources</h2> <p>We self-generate energy from renewable sources through investment in new technologies</p>  





# Kitchen

# Quality products for cleaning and hygiene in professional kitchens

Cleanliness and hygiene in professional kitchens are essential to ensure food and drink safety for customers. Washing, storage and cooking areas must be cleaned with quality products and in accordance with specific hygiene procedures that ensure safe food handling.

From dishwashing to surface cleaning and disinfection, Sanitec offers high-performance solutions to facilitate daily cleaning tasks in professional kitchens. Specific formulations have been developed to remove all types of dirt and preserve the different surfaces in the kitchen.



## THE STEPS IN THE MECHANICAL DISHWASHING PROCESS

### PHASE 1



### SOAKING

Soaking has the function of **removing the most stubborn dirt** before the dishes enter the dishwasher

### PHASE 2



### WASHING

The main wash cycle **attacks, dissolves and holds the dirt** from the dishes in suspension.

It is important at this stage to have the correct level of alkalinity to allow the product to act more effectively, saponifying oils and fats to make them water-soluble

### PHASE 3



### RINSING

The purpose of rinsing is **to remove cleaning solution residues and the dirt particles** in suspension

**Adding rinse aid helps the dishes dry better**, reducing the surface tension of the water and preventing limescale deposits on dishes and the machine

PRODUCTS	SOAKING	WASHING	RINSING
<b>STOVIL GREEN POWER</b> Code 4017 and 4018 - Ecolabel Certificate		●	
<b>STOVIL ULTRA</b> Code 1140 and 1144		●	
<b>STOVIL POWER</b> Code 1120 and 1123		●	
<b>STOVIL ACTIVE</b> Code 1100 and 1103		●	
<b>STOVIL OSMOS</b> Code 1180		●	
<b>STOVIL CHLOR</b> Code 1172 and 1168		●	
<b>STOVIL BAR</b> Code 1110		●	
<b>STOVIL FAST</b> Code 1166	●	●	
<b>STOVIL TABS</b> Code 1160		●	
<b>STOVIL GEL</b> Code 1161-S and 1104	●	●	
<b>BRILL GREEN POWER</b> Code 4019 and 4020 - Ecolabel Certificate			●
<b>BRILL ULTRA</b> Code 1150 and 1153			●
<b>BRILL POWER</b> Code 1130 and 1134			●
<b>BRILL OSMOS</b> Code 1191			●
<b>TRILOGY WASH T1</b> Code 4012		●	
<b>TRILOGY BOOST T2</b> Code 4013		●	
<b>TRILOGY RINSE T3</b> Code 4014			●

# PRODUCTS AND SURFACES: DISHWASHING

## DESCALING / PERIODIC CLEANING OF DISHWASHERS

Dekal - 1950



## MECHANICAL DISH WASHING

Stovil Ultra - 1140, 1144

Stovil Power - 1120, 1123

Stovil Active - 1100, 1103

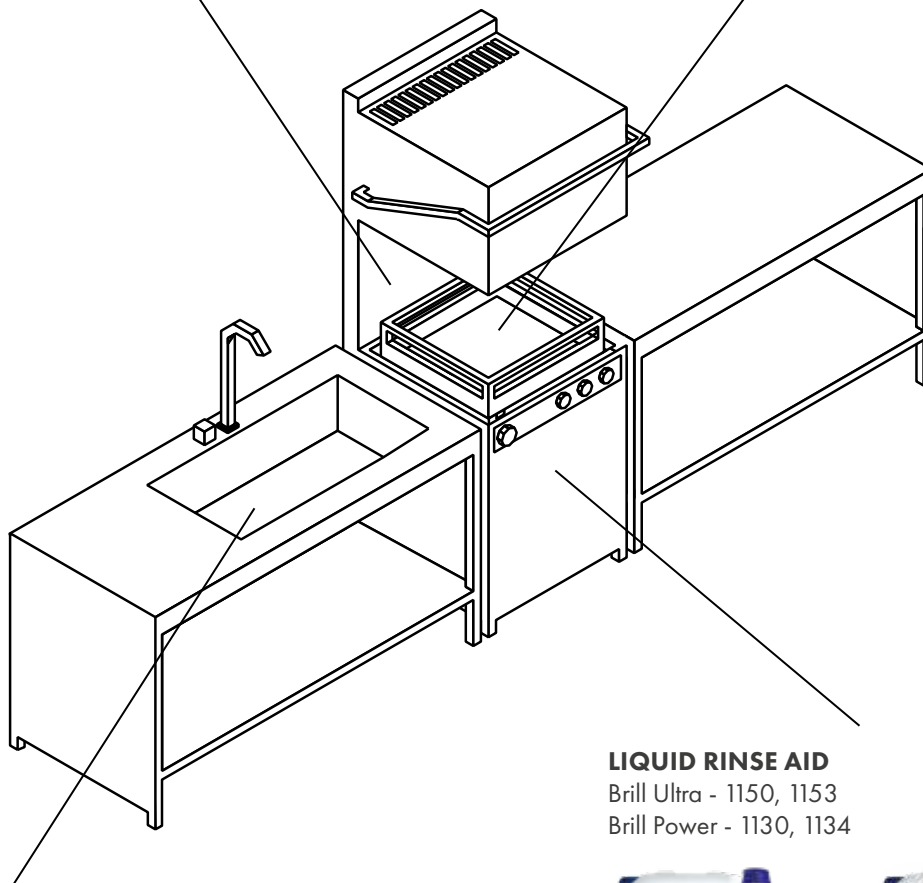

## LIQUID RINSE AID

Brill Ultra - 1150, 1153

Brill Power - 1130, 1134



## HAND DISHWASHING AND SOAKING

Stovil Fast - 1166

Neopol - 1274, 1276, 1231, 1230, 1271, 1270

Washup - 1242-S, 1240

Washup Powder - 1291



# PRODUCTS AND SURFACES: FOOD PREPARATION

## OVEN CLEANING

Fornonet - 1960-S, 1961  
Oven Power - 1965  
Brill Oven - 1967



## SPECIFIC SURFACES

Induction Hobs - 1836  
Inox - 1875-S  
SteelPro - 1813  
Silver - 1881

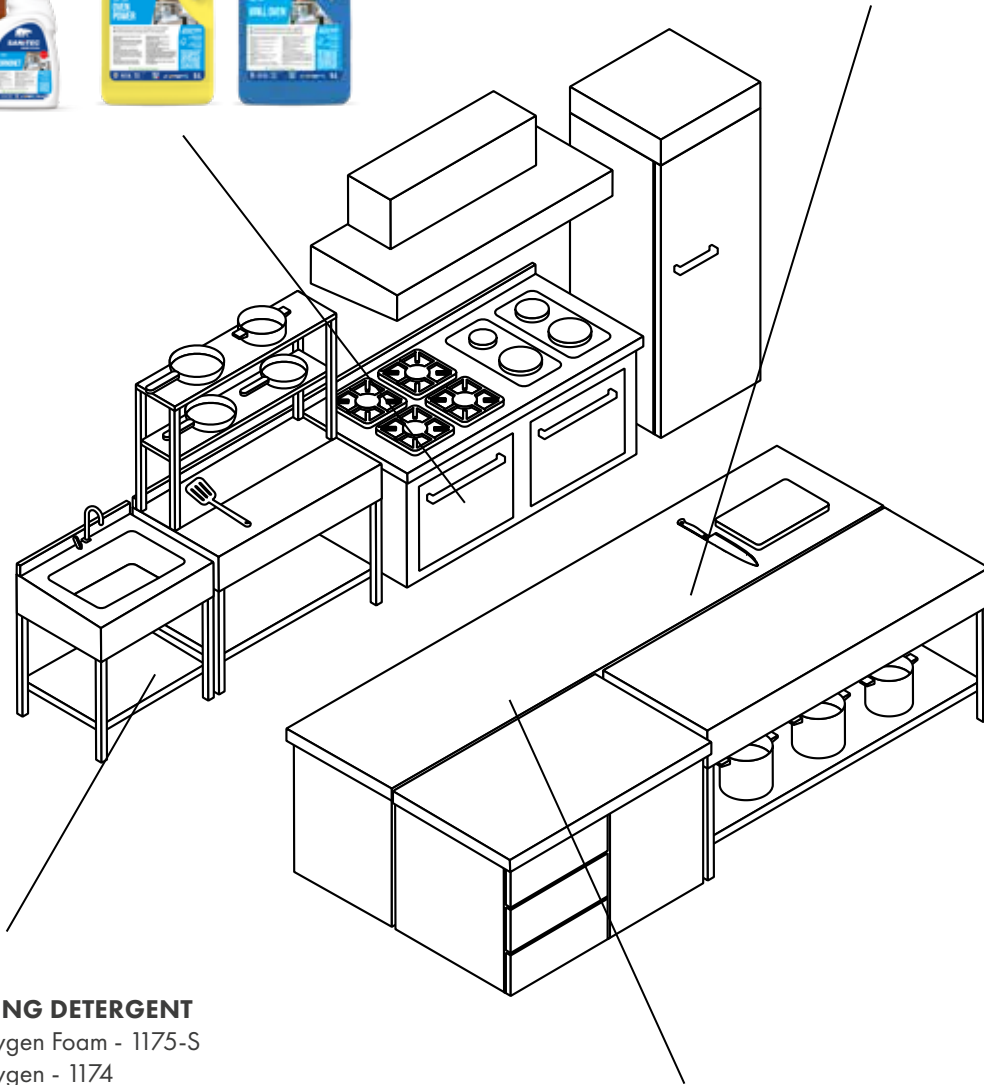

## WHITENING DETERGENT

Active Oxygen Foam - 1175-S  
Active Oxygen - 1174  
Active Chlor - 1560-S, 1173  
Active Chlor Gel - 1562-S



## FOOD CONTACT SURFACE CLEANING FOOD PREPARATION EQUIPMENT CLEANING (E.G. BLENDER, SLICER)

Degrease Ultra - 1810-S, 1801, 1808-S, 1809  
Sani Active - 1804-S  
Multi Activ - 1821-S, 1838-S, 1822-S  
Sanimed - 1511



# ANALYSIS OF POSSIBLE PROBLEMS IN THE MECHANICAL DISHWASHING PROCESS

## WASHING PHASE

probable causes of the issue

PROBLEM	CAUSE	Clogged washing nozzles	Rinse not working	Detergent concentration too high	Detergent concentration too low	Washing temperature too high	Washing temperature too low	Rinse aid concentration too high	Rinse aid concentration too low	Leaks in the loading solenoid valve	Leaks in the rinsing solenoid valve	Defective water softener	Poor elimination of food residues	Poorly positioned dishes	Dosing unit not functioning	Too much hand dishwashing detergent for soaking	Overflow/discharge with leakage (even partial)	Using hand dishwashing detergent for pre-wash
STREAKING			●	●					●			●			●			
RESIDUES ON DISHES		●	●		●	●	●						●	●	●		●	
HIGH DETERGENT CONSUMPTION				●						●	●	●	●				●	
FOAM			●			●		●			●		●		●	●	●	●
DIRTY DISHWASHER					●						●	●	●		●		●	
WET DISHES		●							●		●							

## RINSING PHASE

probable causes of the issue

PROBLEM	CAUSE	Clogged nozzles	Rinsing temperature too high	Rinsing temperature too low	Rinse aid setting too high	Rinse aid setting too low	Dosing unit not functioning	Leaks in the rinsing pipe	Wrongly arranged dishes	Rinsing arm rotation too high	No rotation of rinsing arms	Rinsing pressure too low
STAINS AND STREAKS						●	●		●		●	●
WET DISHES				●		●	●		●			●
DETERGENT ON DISHES		●		●				●	●	●	●	●
FOOD RESIDUES			●					●	●	●	●	●
TOO MUCH RINSE AID					●			●				●
TOO LITTLE RINSE AID						●	●					

## STOVIL GREEN POWER



Alkaline liquid detergent concentrate **Ecolabel-certified**, for mechanical dishwashing, for all water hardnesses

- EU Ecolabel-certified product with low environmental impact
- Effectively removes encrusted grease and food residues
- Prevents limescale build-up on dishes
- Excellent rinsability

**Directions:** To be used with Sanitec automatic dispensers, or in combination with dosing systems integrated into the machine when present.

**Dosage:** Adjust the dispenser to 1-3.5 ml/L depending on the degree of dirt and water hardness. The recommended dosage refers to the use of the product under optimal conditions. Consult Sanitec Service technical support for dosage adjustment.



**pH**  
13 - 14



	Code	<b>4017</b>	Pcs x Box	2
	EAN	8054633834619	Box x Lyr	18
	Volume	5 L / 6.3 kg	Box x Plt	72



	Code	<b>4018</b>	Pcs x Box	1
	EAN	8054633834626	Box x Lyr	13
	Volume	15 L / 18.9 kg	Box x Plt	52



## STOVIL ULTRA



Concentrated alkaline liquid detergent for mechanical dishwashing, for hard water from 25°f a 50°f

- Effectively removes encrusted grease and food residues
- Prevents limescale build-up on dishes
- Excellent rinsability

**Directions:** To be used with Sanitec automatic dispensers, or in combination with dosing systems integrated into the machine when present.

**Dosage:** Adjust the dispenser to 1-2 ml/L depending on the degree of dirt and water hardness. The recommended dosage refers to the use of the product under optimal conditions. Consult Sanitec Service technical support for dosage adjustment.

**pH**  
13 - 14



	Code	<b>1140</b>	Pcs x Box	2
	EAN	8032680392122	Box x Lyr	18
	Volume	5 L / 6.4 kg	Box x Plt	72



	Code	<b>1144</b>	Pcs x Box	1
	EAN	8054633830161	Box x Lyr	13
	Volume	15 L / 19.2 kg	Box x Plt	52



## STOVIL POWER



Concentrated alkaline liquid detergent for mechanical dishwashing, for medium waters between 15°f and 25°f

- Effectively removes encrusted grease and food residues
- Prevents limescale build-up on dishes
- Excellent rinsability

**Directions:** To be used with Sanitec automatic dispensers, or in combination with dosing systems integrated into the machine when present.

**Dosage:** Adjust the dispenser to 1-3 ml/L depending on the degree of dirt and water hardness. The recommended dosage refers to the use of the product under optimal conditions. Consult Sanitec Service technical support for dosage adjustment.

**pH**  
13 - 14



	Code	<b>1120</b>	Pcs x Box	2
	EAN	8032680391613	Box x Lyr	18
	Volume	5 L / 6.2 kg	Box x Plt	72



	Code	<b>1123</b>	Pcs x Box	1
	EAN	8054633830154	Box x Lyr	13
	Volume	15 L / 18.5 kg	Box x Plt	52

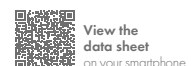

# MECHANICAL DISHWASHING

## STOVIL ACTIVE



Concentrated alkaline liquid detergent for mechanical dishwashing, for soft water below 15°f

- Effectively removes encrusted grease and food residues
- Prevents limescale build-up in the dishwasher
- Excellent rinsability

**Directions:** To be used with Sanitec automatic dispensers, or in combination with dosing systems integrated into the machine when present.

**Dosage:** Adjust the dispenser to 3-5 ml/L depending on the degree of dirt and water hardness. The recommended dosage refers to the use of the product under optimal conditions. Consult Sanitec Service technical support for dosage adjustment.

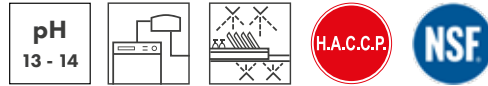

Code	<b>1100</b>	Pcs x Box	2
EAN	8032680390340	Box x Lyr	18
Volume	5 L / 5.7 kg	Box x Plt	72



View the data sheet on your smartphone.



Code	<b>1103</b>	Pcs x Box	1
EAN	8054633830147	Box x Lyr	13
Volume	15 L / 16.9 kg	Box x Plt	52



View the data sheet on your smartphone.

## STOVIL OSMOS



Concentrated alkaline liquid detergent for mechanical dishwashing, specifically for osmosis water

- Effectively removes encrusted grease and food residues
- Prevents limescale build-up on dishes
- Excellent rinsability thanks to the controlled foam formulation

**Directions:** To be used with Sanitec automatic dispensers, or in combination with dosing systems integrated into the machine when present.

**Dosage:** Adjust the dispenser to 1-3 ml/L depending on the degree of dirt and water hardness. The recommended dosage refers to the use of the product under optimal conditions. Consult Sanitec Service technical support for dosage adjustment.



Code	<b>1180</b>	Pcs x Box	2
EAN	8054633838693	Box x Lyr	18
Volume	5 L / 5.7 kg	Box x Plt	72



View the data sheet on your smartphone.

## STOVIL CHLOR

Product pending registration as **Biocide**



Alkaline chlorinated liquid detergent for mechanical dishwashing, for all water hardnesses

- Whitening action
- Effectively removes grease and oxidizable stains such as coffee, tea and lipstick
- Removes odours
- Excellent rinsability

**Directions:** To be used with Sanitec automatic dispensers, or in combination with dosing systems integrated into the machine when present.

**Dosage:** Adjust the dispenser to 2-4 ml/L depending on the degree of dirt and water hardness. The recommended dosage refers to the use of the product under optimal conditions. Consult Sanitec Service technical support for dosage adjustment.

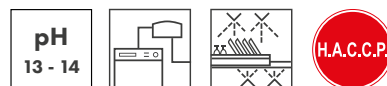

Code	<b>1172</b>	Pcs x Box	2
EAN	8054633830079	Box x Lyr	18
Volume	5 L / 5.8 kg	Box x Plt	72



View the data sheet on your smartphone.



Code	<b>1168</b>	Pcs x Box	1
EAN	8054633830086	Box x Lyr	13
Volume	15 L / 17.3 kg	Box x Plt	52



View the data sheet on your smartphone.

## STOVIL BAR



Concentrated alkaline liquid detergent for cups, mugs, glasses, cutlery and small dishes in general, for all water hardnesses

- Effectively removes coffee, tea and lipstick stains
- Effectively removes encrusted grease and food residues
- Prevents limescale build-up on dishes
- Excellent rinsability

**Directions:** Ideal for cup washers, glass washers and small undercounter dishwashers. To be used with Sanitec automatic dispensers, or in combination with dosing systems integrated into the machine when present.

**Dosage:** Adjust the dispenser to 1-2 ml/L depending on the degree of dirt and water hardness. The recommended dosage refers to the use of the product under optimal conditions. Consult Sanitec Service technical support for dosage adjustment.

**pH**  
13 - 14



Code	<b>1110</b>	Pcs x Box	2
EAN	8032680391583	Box x Lyr	18
Volume	5 L / 6.1 kg	Box x Plt	72



View the data sheet on your smartphone.

## STOVIL FAST



Dual action alkaline liquid detergent:

- 1) Mechanical washing of delicate materials such as aluminium, light alloys, etc.
- 2) Dish soaking function, for all water hardness levels

- Effectively removes encrusted grease and food residues
- Prevents limescale build-up on dishes
- Excellent rinsability thanks to the formulation with controlled foam surfactants

**Directions:** To be used for soaking dishes when the dirt is significant. Mechanical washing: the product is normally dosed using Sanitec automatic dosing equipment, or in combination with dosing systems integrated into the machine when present.

**Dosage:** Adjust the dispenser from 3 to 5 ml/L depending on the degree of dirt and water hardness. Soaking: dilute the product in hot water at a rate of 5 to 10 ml/L (0.5-1 capful every 5 litres) depending on the degree of dirt. Immerse the dishes in the solution for 10-15 minutes. For stubborn dirt, leave the dishes to soak for longer. Then continue with normal washing.

**pH**  
12 - 13



Code	<b>1166</b>	Pcs x Box	2
EAN	8054633830925	Box x Lyr	18
Volume	5 L / 5.4 kg	Box x Plt	72



View the data sheet on your smartphone.

## STOVIL TABS



Dishwasher detergent tablets for mechanical dishwashing, for all water hardnesses

Six actions with one tablet:

1. Optimal dirt removal
2. Anti-limescale and anti-stain action
3. Rinse aid action
4. Oxidizing action with active oxygen
5. Lemon-scented odour remover
6. Active protection of dishes and glasses

**Directions:** Dishwashers without a tray: unwrap the tablet and place it in the appropriate tray. Professional dishwashers: place the tablet directly into the wash tub. Each tablet lasts 5-8 cycles.

**pH**  
10,3 - 11,3



Code	<b>1160</b>	Pcs x Box	6
EAN	8032680394577	Box x Lyr	12
Volume	60 tabs	Box x Plt	84



View the data sheet on your smartphone.

# MECHANICAL DISHWASHING

## STOVIL GEL



Rinse-aid detergent for mechanical dishwashing, for all water hardnesses

- Effectively removes encrusted grease and food residues
- Prevents limescale build-up on dishes
- Excellent rinsability thanks to the formulation with controlled foam surfactants

**Directions:** Professional dishwashers: the product is dosed using Sanitec automatic dosing equipment, or in combination with dosing systems integrated into the machine, where present.

**Dosage:** Adjust the dispenser to 2-4 ml/L depending on the degree of dirt and water hardness. Domestic dishwashers: pour the product into the appropriate detergent compartment (1 dose = 25 ml).

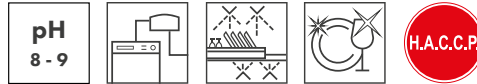

Code	<b>1161-S</b>	Pcs x Box	6
EAN	8032680397561	Box x Lyr	21
Volume	1000 ml	Box x Plt	105



View the data sheet on your smartphone.



Code	<b>1104</b>	Pcs x Box	2
EAN	8054633832011	Box x Lyr	18
Volume	5 L / 5.5 kg	Box x Plt	72



View the data sheet on your smartphone.

## BRILL GREEN POWER



Rinse aid, **Ecolabel-certified**, for mechanical dishwashing, for all water hardnesses

- EU Ecolabel-certified product with low environmental impact
- Speeds up the drying of dishes, also effective on plastic
- Eliminates bad odours
- Reduces limescale build-up on dishes

**Directions:** To be used with Sanitec automatic dispensers, or in combination with dosing systems integrated into the machine when present.

**Dosage:** Adjust the dispenser to 1-2 ml/L depending on the degree of dirt and water hardness. The recommended dosage refers to the use of the product under optimal conditions. Consult Sanitec Service technical support for dosage adjustment.



Code	<b>4019</b>	Pcs x Box	2
EAN	8054633834633	Box x Lyr	18
Volume	5 L / 5.4 kg	Box x Plt	72



View the data sheet on your smartphone.



Code	<b>4020</b>	Pcs x Box	1
EAN	8054633834640	Box x Lyr	13
Volume	15 L / 16.2 kg	Box x Plt	52



View the data sheet on your smartphone.

## BRILL ULTRA



Concentrated acid rinse aid for mechanical dishwashing, for hard water over 25°f

- Speeds up the drying of dishes, also effective on plastic
- Leaves dishes sparkling clean without streaks and water stains
- Eliminates bad odours
- Prevents the formation of scale in the dishwasher
- Excellent rinsability thanks to the formulation with controlled foam surfactants

**Directions:** The product is dosed using Sanitec automatic dosing equipment, or in combination with dosing systems integrated into the machine when present.

**Dosage:** Adjust the dispenser to 0.2-0.5 ml/L depending on the degree of dirt and water hardness. The recommended dosage refers to the use of the product under optimal conditions. Consult Sanitec Service technical support for dosage adjustment.



Code	<b>1150</b>	Pcs x Box	2
EAN	8032680393105	Box x Lyr	18
Volume	5 L / 5.1 kg	Box x Plt	72



View the data sheet on your smartphone.



Code	<b>1153</b>	Pcs x Box	1
EAN	8054633830093	Box x Lyr	13
Volume	15 L / 15.3 kg	Box x Plt	52



View the data sheet on your smartphone.

## BRILL POWER



Concentrated acid rinse aid for mechanical dishwashing, for medium and soft water up to 25°f

- Speeds up the drying of dishes, also effective on plastic
- Leaves dishes sparkling clean without streaks and water stains
- Neutralizes caustic residues that ruin glass
- Eliminates bad odours
- Prevents the formation of scale in the dishwasher
- Excellent rinsability thanks to the formulation with controlled foam surfactants

**Directions:** The product is dosed using Sanitec automatic dosing equipment, or in combination with dosing systems integrated into the machine when present.

**Dosage:** Adjust the dispenser to 0.2-0.5 ml/L depending on the degree of dirt and water hardness. The recommended dosage refers to the use of the product under optimal conditions. Consult Sanitec Service technical support for dosage adjustment.

pH  
1,6 - 2,6



Code	1130	Pcs x Box	2
EAN	8032680391644	Box x Lyr	18
Volume	5 L / 5.1 kg	Box x Plt	72



View the data sheet on your smartphone.



Code	1134	Pcs x Box	1
EAN	8054633830178	Box x Lyr	13
Volume	15 L / 15.3 kg	Box x Plt	52



View the data sheet on your smartphone.

## BRILL OSMOS



Rinse aid for mechanical dishwashing specifically for osmosis water

- Speeds up the drying of dishes, also effective on plastic
- Leaves dishes sparkling clean without streaks and water stains
- Neutralizes caustic residues that ruin glass
- Eliminates bad odours
- Prevents the formation of scale in the dishwasher
- Excellent rinsability thanks to the formulation with controlled foam surfactants

**Directions:** To be used with Sanitec automatic dispensers, or in combination with dosing systems integrated into the machine when present.

**Dosage:** Adjust the dispenser to 0.1-0.3 ml/L depending on the degree of dirt and water hardness. The recommended dosage refers to the use of the product under optimal conditions. Consult Sanitec Service technical support for dosage adjustment.

pH  
4,5 - 5,5



Code	1191	Pcs x Box	2
EAN	8054633838716	Box x Lyr	18
Volume	5 L / 5 kg	Box x Plt	72



View the data sheet on your smartphone.

## PERISTALTIC DISPENSER FOR DETERGENT



**PR4** - Peristaltic detergent dispenser for glasswashers and dishwashers

**PA6** - Peristaltic detergent dispenser with conductivity probe for tunnel dishwashers and pot washers

PR4  
dispenser

Code	5	Pcs x Box	1
EAN	8032680395390	Box x Lyr	-
Volume	-	Box x Plt	-

PA6  
dispenser

Code	37	Pcs x Box	1
EAN	8032680396533	Box x Lyr	-
Volume	-	Box x Plt	-

# MECHANICAL DISHWASHING

## PERISTALTIC DISPENSER FOR RINSE AID



**PR1** - Peristaltic rinse aid dispenser for glasswashers, dishwashers, tunnel washers and pot washers

<b>PR1</b> dispenser	Code	6	Pcs x Box	1
	EAN	8032680395406	Box x Lyr	-
	Volume	-	Box x Plt	-

## PERISTALTIC PUMP FOR DETERGENT



The single pump has been designed for dosing liquid detergent in the dishwasher

- Highly resistant to corrosive products thanks to its polypropylene material
- Using a signal programmer or the dishwasher solenoid valves, the desired dosages of detergent are easily obtained during the filling and rinsing phases
- It can be fixed quickly and easily to the wall with 2 screws or with a special support supplied with each pump
- With flow regulation for speed variation

<b>Pump</b> <b>C1R</b>	Code	371	Pcs x Box	1
	EAN	-	Box x Lyr	-
	Volume	-	Box x Plt	-

## PERISTALTIC PUMP FOR RINSE AID



The single pump has been designed for dosing liquid rinse aid in the dishwasher

- Highly resistant to corrosive products thanks to its polypropylene material
- Using a signal programmer or the dishwasher solenoid valves, the desired dosages of rinse aid are easily obtained during the filling and rinsing phases
- It can be fixed quickly and easily to the wall with 2 screws or with a special support supplied with each pump
- With flow regulation for speed variation

<b>Pump</b> <b>AC1R</b>	Code	372	Pcs x Box	1
	EAN	-	Box x Lyr	-
	Volume	-	Box x Plt	-

# The modular Trilogy system



The Trilogy range consists of concentrated formulas of detergent, sequestering agent and rinse aid, the concentration of which is dosed by the control unit according to water hardness and level of dirt. The DBrain control unit allows independent dosing of the three products, controlling their concentration in real time, and monitoring their consumption and costs.

**Less product consumption**  
compared to conventional products thanks to **up to 4 times higher concentration**



**Control of running cost**

## Advantages of the Trilogy system:

- Effective in any wash water condition
- No phosphorous derivatives, EDTA and NTA
- Reliable dosages
- Monitoring and statistical processing of washings

# TRILOGY CONCENTRATED SYSTEM

## TRILOGY WASH T1



Super concentrated alkaline detergent for mechanical dishwashing, for all water hardnesses

- Effectively removes encrusted grease and food residues
- Ensures excellent costs in use thanks to the super-concentrated formula

**Directions:** For use exclusively in professional machines, we recommend using automatic dispensers. Insert the draw tube directly into the tank. Adjust dosage as needed.

**Dosage:** Adjust the dispenser to 0,8-1,2 ml/L depending on the degree of dirt and water hardness. The recommended dosage refers to the use of the product under optimal conditions. Consult Sanitec Service technical support for dosage adjustment.

Product to be used in combination with **Trilogy Boost T2** and **Trilogy Rinse T3**



Code	4012	Pcs x Box	2
EAN	8032680399985	Box x Lyr	18
Volume	5 L / 7.5 kg	Box x Plt	72



View the data sheet on your smartphone.

## TRILOGY BOOST T2



Super concentrated vegetable-based sequestering detergent for mechanical dishwashing, for all water hardnesses

- Promotes the removal of dirt and stains
- Prevents the formation of limescale during the washing phase on the dishes and in the dishwasher
- Ensures excellent costs in use thanks to the super-concentrated formula

**Directions:** For use exclusively in professional machines, we recommend using automatic dispensers. Insert the draw tube directly into the tank. Adjust dosage as needed.

**Dosage:** Adjust the dispenser to 0.8-1.2 ml/L depending on the degree of dirt and water hardness. The recommended dosage refers to the use of the product under optimal conditions. Consult Sanitec Service technical support for dosage adjustment.

Product to be used in combination with **Trilogy Wash T1** and **Trilogy Rinse T3**

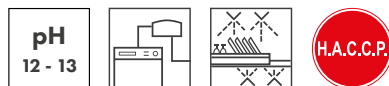

Code	4013	Pcs x Box	2
EAN	8032680399992	Box x Lyr	18
Volume	5 L / 7 kg	Box x Plt	72



View the data sheet on your smartphone.

## TRILOGY RINSE T3



Super concentrated acid rinse aid for mechanical dishwashing, for all water hardnesses

- Leaves dishes sparkling clean without streaks and water stains
- Excellent rinsability thanks to the formulation with controlled foam surfactants
- Ensures excellent costs in use thanks to the super-concentrated formula

**Directions:** For use exclusively in professional machines, we recommend using automatic dispensers. Insert the draw tube directly into the tank. Adjust dosage as needed.

**Dosage:** Adjust the dispenser to 0.1-0.2 ml/L depending on the degree of dirt and water hardness. The recommended dosage refers to the use of the product under optimal conditions. Consult Sanitec Service technical support for dosage adjustment.

Product to be used in combination with **Trilogy Wash T1** and **Trilogy Boost T2**



Code	4014	Pcs x Box	2
EAN	8032680395871	Box x Lyr	18
Volume	5 L / 5.5 kg	Box x Plt	72



View the data sheet on your smartphone.

## TRILOGY CONTROL UNIT

Dosing system with three peristaltic pumps suitable for any type of dishwasher.



- Dispenses concentrated detergent, sequestrant and rinse aid in proportion to the hardness, degree of soiling and water consumption of the dishwasher
- Dedicated software with storage and processing of washing statistics

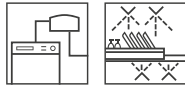

Control unit	Code	370	Pcs x Box	1
	EAN	-	Box x Lyr	-
	Volume	-	Box x Plt	-

## TANK HOLDER BRACKET

Wall bracket for hanging the 5 L tank



- Tidier room
- Increased safety for operators

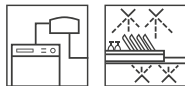

Holder bracket	Code	11847	Pcs x Box	1
	EAN	-	Box x Lyr	-
	Volume	-	Box x Plt	-

## DEKAL GREEN POWER



**Ecolabel-certified** acid descaler for removing limescale from tools, machines and equipment

- EU Ecolabel-certified product with low environmental impact
- When used regularly, it helps maintain the performance of the equipment and increases longevity
- Excellent for recirculating washing also due to its low foaming
- Safe on metals and all types of machinery

**Directions:** Small surfaces/stubborn dirt: apply the product as is directly to the surface to be cleaned, leave to act for a few minutes and then rub with a clean, damp cloth. Rinse thoroughly with water. Soaking: dilute the product at a concentration of 30 ml per litre of hot water (3 caps every 5 litres) depending on the extent of the encrustation. Leave to soak until the limescale deposit has dissolved. If necessary, use a sponge or brush to remove more stubborn limescale deposits. Rinse thoroughly with water. Spray Method: spray on the surface or equipment to be treated. Leave on and rub. Rinse thoroughly with water. Dishwasher/Washing Machine: make sure the machine is completely empty. Pour the product directly into the tray, 30 ml for every litre of water (3 caps for every 5 litres). Run an empty wash cycle at 50-60°C.



Code	<b>3113</b>	Pcs x Box	2
EAN	8054633838730	Box x Lyr	18
Volume	5 L / 5.5 kg	Box x Plt	72



View the data sheet on your smartphone.

## DEKAL



Concentrated acid descaler for removing limescale from utensils, machines and equipment such as dishwashers, boilers and pasta cookers.

- Effectively removes greasy dirt and limescale deposits
- When used regularly, it keeps the performance of the equipment unchanged and increases its longevity
- Excellent rinsability thanks to the formulation with controlled foam surfactants
- Safe on metals and all types of machinery

**Directions:** Soaking: Dilute the product at a concentration of 50 - 150 ml per litre of hot water (5 - 15 caps every 5 litres) depending on the extent of the scale. Leave to soak until the limescale deposit has dissolved. If necessary, use a sponge or brush to remove more stubborn limescale deposits. Rinse thoroughly with water. Spray Method: Spray a solution of 150 ml (15 caps per 5 litres) per litre of water on the surface or equipment to be treated. Leave on and rub. Rinse thoroughly with water. Dishwasher/Washing Machine: Make sure the machine is completely empty. Pour the product directly into the tray, 50 - 150 ml for every litre of water (5-15 caps for every 5 litres). Run an empty wash cycle at 50-60°C.



Code	<b>1950</b>	Pcs x Box	2
EAN	8032680391569	Box x Lyr	18
Volume	5 L / 6.2 kg	Box x Plt	72



View the data sheet on your smartphone.

## NEOPOL GREEN POWER | Unscented



Concentrated liquid detergent, **Ecolabel-certified**, for manual dishwashing

- EU Ecolabel-certified product with low environmental impact
- Effectively removes grease and organic dirt
- Eliminates odours from dishes
- Leaves dishes sparkling without streaks
- Effective cleaning with compact foam and immediate rinsing
- Product with neutral pH, dermatologically tested

**Directions:** Pour the dose of product into warm water, leave the dishes to soak for the time necessary to soften the dirt, when necessary use a sponge/brush directly on the stubborn dirt, then rinse and leave to dry.

**Dosage:** 1-1.2 ml/L per litre of water, depending on the degree of dirt (1 push = 4 ml)



**pH**  
6,5 - 7,5



Code	<b>3106</b>	Pcs x Box	6
EAN	8054633838600	Box x Lyr	15
Volume	1000 ml	Box x Plt	90



View the data sheet on your smartphone.



Code	<b>3104</b>	Pcs x Box	2
EAN	8032680393662	Box x Lyr	18
Volume	5 L / 5.2 kg	Box x Plt	72



View the data sheet on your smartphone.

## SANI NEOPOL



Concentrated sanitizing liquid detergent with lactic acid for manual dishwashing

- Effectively removes grease and organic dirt
- Eliminates odours from dishes
- Leaves dishes sparkling without streaks
- Effective cleaning with compact foam and immediate rinsing
- Product with neutral pH, dermatologically tested

**Directions:** Pour the dose of product into warm water, leave the dishes to soak for the time necessary to soften the dirt, when necessary use a sponge/brush directly on the stubborn dirt, then rinse and leave to dry.

**Dosage:** 1-3 ml/L per litre of water, depending on the degree of dirt. (1 push = 4 ml).

**pH**  
5 - 6



Code	<b>1274</b>	Pcs x Box	6
EAN	8054633838614	Box x Lyr	15
Volume	1000 ml	Box x Plt	90



View the data sheet on your smartphone.



Code	<b>1276</b>	Pcs x Box	2
EAN	8054633838617	Box x Lyr	18
Volume	5 L / 5.1 kg	Box x Plt	72



View the data sheet on your smartphone.

## NEOPOL | Citrus



Concentrated liquid detergent for manual dishwashing

- Effectively removes grease and organic dirt
- Eliminates odours from dishes thanks to its fresh, citrus scent
- Leaves dishes sparkling without streaks
- Effective cleaning with compact foam and immediate rinsing
- Product with neutral pH, dermatologically tested

**Directions:** Pour the dose of product into warm water, leave the dishes to soak for the time necessary to soften the dirt, when necessary use a sponge/brush directly on the stubborn dirt, then rinse and leave to dry.

**Dosage:** 1-3 ml/L per litre of water, depending on the degree of dirt (1 push = 4 ml).

**pH**  
6,5 - 7,5



Code	<b>1231</b>	Pcs x Box	6
EAN	8054633838600	Box x Lyr	15
Volume	1000 ml	Box x Plt	90



View the data sheet on your smartphone.



Code	<b>1230</b>	Pcs x Box	2
EAN	8032680393662	Box x Lyr	18
Volume	5 L / 5.2 kg	Box x Plt	72



View the data sheet on your smartphone.

# HAND DISHWASHING

## NEOPOL | Lemon



Concentrated liquid detergent for manual dishwashing

- Effectively removes grease and organic dirt
- Eliminates odours from dishes thanks to its lemon scent
- Leaves dishes sparkling without streaks
- Effective cleaning with compact foam and immediate rinsing
- Product with neutral pH, dermatologically tested

**Directions:** Pour the dose of product into warm water, leave the dishes to soak for the time necessary to soften the dirt, when necessary use a sponge/brush directly on the stubborn dirt, then rinse and leave to dry.  
**Dosage:** 1-3 ml/L per litre of water, depending on the degree of dirt (1 push = 4 ml).



Code	1271	Pcs x Box	6
EAN	8054633830796	Box x Lyr	15
Volume	1000 ml	Box x Plt	90



View the data sheet on your smartphone.



Code	1270	Pcs x Box	2
EAN	8032680392825	Box x Lyr	18
Volume	5 L / 5.2 kg	Box x Plt	72



View the data sheet on your smartphone.

## WASHUP | Green Lemon



Liquid detergent for manual dishwashing

- Degreases thoroughly
- Leaves a pleasant fragrance
- Leaves dishes sparkling without streaks
- Product with neutral pH, dermatologically tested

**Directions:** Pour the dose of product into warm water, leave the dishes to soak for the time necessary to soften the dirt, when necessary use a sponge/brush directly on the stubborn dirt, then rinse and leave to dry.  
**Dosage:** 4-6 ml/L per litre of water, depending on the degree of dirt.



Code	1242-5	Pcs x Box	6
EAN	8032680393150	Box x Lyr	15
Volume	1000 ml	Box x Plt	90



View the data sheet on your smartphone.



Code	1240	Pcs x Box	2
EAN	8032680391729	Box x Lyr	18
Volume	5 L / 5.1 kg	Box x Plt	72



View the data sheet on your smartphone.

## WASHUP POWDER | Green Lemon



Powder detergent for manual dishwashing

- Degreases thoroughly
- Leaves a pleasant fragrance
- Leaves dishes sparkling without streaks
- Product with neutral pH, dermatologically tested

**Directions:** Pour the dose of product into warm water, leave the dishes to soak for the time necessary to soften the dirt, when necessary use a sponge/brush directly on the stubborn dirt, then rinse and leave to dry.  
**Dosage:** Dosage depending on water hardness and degree of dirt: Soft water 0 -15 °f: 2 - 3 g/L of water. Medium water 16-25 °f: 4 - 5 g/L of water. Hard water over 25 °f: For every 5 °f = 1 g/L more.



Code	1291	Pcs x Box	1
EAN	8050999573544	Box x Lyr	5
Volume	8 kg	Box x Plt	60



View the data sheet on your smartphone.

**SANI ACTIVE** | Unscented



Universal bactericidal and yeasticidal degreaser according to **Italian Ministry of Health**, Registration no. 20440.

- Eliminates 99.9% of bacteria and fungi
- Ideal in all cases where cleaning and disinfection are required in a single operation
- Disinfects and degreases all surfaces in the kitchen, bathroom, offices, and other public environments, cars and waste collection containers, even in the presence of stubborn dirt
- Also recommended for the agri-food and healthcare sectors, on food contact surfaces, and for those in contact with elderly people and children

**Directions:** For normal cleaning, spray directly to the surface to be treated and then dry with a cloth or paper. To disinfect, spray and leave on for at least 15 minutes, then dry with a cloth, paper or rinse.

**Dosage:** See the terms of use in the table.



Code	<b>1804-S</b>	Pcs x Box	6
EAN	8054633834602	Box x Lyr	21
Volume	750 ml	Box x Plt	105



View the data sheet on your smartphone.

**Active ingredient**

N-(3-aminopropyl)-N-dodecylpropane-1,3-diamine 0.32 g/100 g



**Product code** 1804-S

**Active ingredient** N-(3-aminopropyl)-N-dodecylpropane-1,3-diamine 0.32 g/100 g

**Bactericidal efficacy**

**Fungicidal efficacy**

**Regulation**

UNI EN 1276:2009  
UNI EN 13697:2015

UNI EN 1650:2013  
UNI EN 13697:2015

**Tested organisms**

Pseudomonas aeruginosa  
Staphylococcus aureus  
Enterococcus hirae  
Escherichia coli

Candida albicans

**Conditions of use**

Concentration: Ready to use  
Contact time: 5 minutes  
Dirt conditions

Concentration: Ready to use  
Contact time: 15 minutes  
Dirt conditions

**MULTI ACTIV** | Unscented



Ready-to-use disinfectant for surfaces according to **Italian Ministry of Health**, Registration no. 20058.

- Eliminates 99.9% of bacteria, fungi and viruses
- Cleans and eliminates bad odours
- Effectively removes gram-positive and gram-negative bacteria, fungi, moulds, and both enveloped and non-enveloped viruses from smooth surfaces, thanks to its formulation with active ingredients
- Suitable for disinfecting kitchens, bathrooms and all surfaces in contact with food

**Directions:** For normal cleaning, apply directly to the surface to be treated and then dry with a cloth or paper. For disinfection, leave on for at least 5 minutes to obtain bactericidal action or for at least 15 minutes to also obtain fungicidal and virucidal action. For virucidal action, apply the product to the previously cleaned surface. When disinfecting surfaces that may come into direct contact with food, rinse with potable water.

**Dosage:** See the terms of use in the table.



Code	<b>1821-S</b>	Pcs x Box	6
EAN	8032680391446	Box x Lyr	21
Volume	750 ml	Box x Plt	105



View the data sheet on your smartphone.

**Active ingredient**

Alkyl dimethylbenzyl ammonium chloride 0.4 g/100 g

## MULTI ACTIV | Lemon



Ready-to-use disinfectant for surfaces according to **Italian Ministry of Health**, Registration no. 20058.

- Eliminates 99.9% of bacteria, fungi and viruses
- Cleans and eliminates bad odours
- Effectively removes gram-positive and gram-negative bacteria, fungi, moulds, and both enveloped and non-enveloped viruses from smooth surfaces, thanks to its formulation with active ingredients
- Suitable for disinfecting kitchens, bathrooms and all surfaces in contact with food

**Directions:** For normal cleaning, apply directly to the surface to be treated and then dry with a cloth or paper. For disinfection, leave on for at least 5 minutes to obtain bactericidal action or for at least 15 minutes to also obtain fungicidal and virucidal action. For virucidal action, apply the product to the previously cleaned surface. When disinfecting surfaces that may come into direct contact with food, rinse with potable water.

**Dosage:** See the terms of use in the table.



Code	1838-S	Pcs x Box	6
EAN	8054633838013	Box x Lyr	21
Volume	750 ml	Box x Plt	105



View the data sheet on your smartphone.

### Active ingredient

Alkyl dimethylbenzyl ammonium chloride 0.4 g/100 g

## MULTI ACTIV | Pine



Ready-to-use disinfectant for surfaces according to **Italian Ministry of Health**, Registration no. 20058.

- Eliminates 99.9% of bacteria, fungi and viruses
- Cleans and eliminates bad odours
- Effectively removes gram-positive and gram-negative bacteria, fungi, moulds, and both enveloped and non-enveloped viruses from smooth surfaces, thanks to its formulation with active ingredients
- Suitable for disinfecting kitchens, bathrooms and all surfaces in contact with food

**Directions:** For normal cleaning, apply directly to the surface to be treated and then dry with a cloth or paper. For disinfection, leave on for at least 5 minutes to obtain bactericidal action or for at least 15 minutes to also obtain fungicidal and virucidal action. For virucidal action, apply the product to the previously cleaned surface. When disinfecting surfaces that may come into direct contact with food, rinse with potable water.

**Dosage:** See the terms of use in the table.



Code	1822-S	Pcs x Box	6
EAN	8032680392009	Box x Lyr	21
Volume	750 ml	Box x Plt	105



View the data sheet on your smartphone.

### Active ingredient

Alkyl dimethylbenzyl ammonium chloride 0.4 g/100 g



**Product code** 1821-S, 1838-S, 1822-S

**Active ingredient** Alkyl dimethylbenzyl ammonium chloride 0.4 g/100 g

### Bactericidal efficacy

### Fungicidal efficacy

### Virucidal efficacy

### Regulation

UNI EN 1276:2009  
UNI EN 13697:2015

UNI EN 1650:2008  
UNI EN 13697:2001

UNI EN 14476:2019  
UNI EN 16777:2019

### Tested organisms

Pseudomonas aeruginosa  
Staphylococcus aureus  
Enterococcus hirae  
Escherichia coli

Candida albicans  
Penicillium verrucosum

Vaccinia virus  
Adenovirus type 5,  
Murine norovirus MNV

### Conditions of use

Concentration: Ready to use  
Contact time: 5 minutes  
Dirt conditions

Concentration: Ready to use  
Contact time: 15 minutes  
Dirt conditions

Concentration: Ready to use  
Contact time: 15 minutes  
Clean conditions

**SANIMED** | Unscented



Concentrated disinfectant for surfaces according to **Italian Ministry of Health**, Registration no. 20047

- Eliminates 99.9% of bacteria, fungi and viruses
- Fungicidal, bactericidal and virucidal action, active against gram-positive and gram-negative bacteria, fungi, moulds and viruses, both enveloped and non-enveloped, present in domestic and professional environments
- Particularly suitable for disinfecting surfaces and equipment in the agri-food, hotel and catering industries
- It is also suitable for use in high traffic environments, such as bathrooms in public places, outpatient clinics and hospital environments

**Directions:** Dilute SANIMED® in water and spray or spread with a sponge or mop. For small utensils, immerse the material to be disinfected. When disinfecting surfaces that may come into direct contact with food, rinse with potable water. For virucidal action, apply the product to the previously cleaned surface, in a 5% solution equal to 250 ml per 5 litres of water.

**Dosage:** For normal cleaning dilute SANIMED® at 0.5%, equal to 25 ml per 5 litres of water. For disinfection, dilute SANIMED® at 1.5%, equal to 75 ml per 5 litres of water and leave to act for at least 5 minutes for bactericidal activity or at least 15 minutes for fungicidal and virucidal activity.



Code	1511	Pcs x Box	2
EAN	8032680391248	Box x Lyr	18
Volume	5 L / 5 kg	Box x Plt	72



View the data sheet on your smartphone.

**Active ingredient**

Alkyl dimethylbenzyl ammonium chloride 10 g/100 g



**Product code** 1511

**Active ingredient** Alkyl dimethylbenzyl ammonium chloride 10 g/100 g

	<b>Bactericidal efficacy</b>	<b>Fungicidal efficacy</b>	<b>Virucidal efficacy</b>
<b>Regulation</b>	UNI EN 1276:2009 UNI EN 13697:2015	UNI EN 1650:2008 UNI EN 13697:2001	UNI EN 14476:2019 UNI EN 16777:2019
<b>Tested organisms</b>	Pseudomonas aeruginosa Staphylococcus aureus Enterococcus hirae Escherichia coli	Candida albicans Penicillium verrucosum	Vaccinia virus Adenovirus type 5, Murine norovirus MNV
<b>Conditions of use</b>	Concentration: 1.5% Contact time: 5 minutes Dirt conditions	Concentration: 1.5% Contact time: 15 minutes Dirt conditions	Concentration: 5% Contact time: 15 minutes Clean conditions

## ULTRA DEGREASER GREEN POWER



Ecolabel-certified universal degreaser for stubborn dirt

- EU Ecolabel-certified product with low environmental impact
- Effectively removes dirt, grease, oil and charred residues
- Ideal for the catering sector, industry, garages, offices, warehouses, hospitals

**Directions:** Dispense the product directly onto the surface to be cleaned, allow it to act for a few minutes and then wipe with a clean, damp cloth. Rinse thoroughly with water.

**Dosage:** Ready to use.

**pH**  
10 - 11



Code	<b>3101</b>	Pcs x Box	6
EAN	8032680393693	Box x Lyr	21
Volume	750 ml	Box x Plt	105



View the data sheet on your smartphone.

## DEGREASER ULTRA | Lemon



Universal degreaser for stubborn dirt

- Degreasing and sanitizing action
- Effectively removes organic dirt, grease, oil and charred residues
- Leaves a pleasant scent in the room

**Directions:** Dispense the product directly onto the surface to be cleaned, allow it to act for a few minutes and then wipe with a clean, damp cloth. Rinse thoroughly with water.

**Dosage:** Ready to use.

**pH**  
10 - 11



Code	<b>1810-S</b>	Pcs x Box	6
EAN	8032680392689	Box x Lyr	21
Volume	750 ml	Box x Plt	105



View the data sheet on your smartphone.



Code	<b>1801</b>	Pcs x Box	2
EAN	8032680391385	Box x Lyr	18
Volume	5 L / 5,1 kg	Box x Plt	72



View the data sheet on your smartphone.

## DEGREASER ULTRA | Marseille



Universal degreaser for stubborn dirt

- Degreasing and sanitizing action
- Effectively removes organic dirt, grease, oil and charred residues
- Leaves a pleasant scent in the room

**Directions:** Dispense the product directly onto the surface to be cleaned, allow it to act for a few minutes and then wipe with a clean, damp cloth. Rinse thoroughly with water.

**Dosage:** Ready to use.

**pH**  
10 - 11



Code	<b>1808-S</b>	Pcs x Box	6
EAN	8032680391330	Box x Lyr	21
Volume	750 ml	Box x Plt	105



View the data sheet on your smartphone.



Code	<b>1809</b>	Pcs x Box	2
EAN	8032680391354	Box x Lyr	18
Volume	5 L / 5,1 kg	Box x Plt	72



View the data sheet on your smartphone.

## ACTIVE CHLOR FOAM

Product pending registration as **Biocide**



Sodium hypochlorite-based degreasing and whitening detergent for hard surfaces

- Cleans, deodorizes and removes stains in a single solution
- It degreases thoroughly and is also effective on pigmented dirt
- It forms a compact foam that also adheres to vertical walls
- Easy to rinse
- Whitening effect on grouting

**Directions:** Dispense the product directly onto the surface to be cleaned, allow it to act for a few minutes and then wipe with a clean, damp cloth. Rinse thoroughly with water.

**Dosage:** Ready to use.

pH  
12 - 13



Code	1560-S	Pcs x Box	6
EAN	8032680393167	Box x Lyr	21
Volume	750 ml	Box x Plt	105



View the data sheet on your smartphone.

## ACTIVE CHLOR

Product pending registration as **Biocide**



Concentrated liquid detergent based on non-foaming sodium hypochlorite for hard surfaces

- Cleans, deodorizes and removes stains in a single solution
- Effectively removes stubborn dirt
- Eliminates unpleasant odours
- Easy rinsing thanks to its non-foaming formula

**Directions:** Ideal for places open to the public such as hospitals, schools, hotels, changing rooms, toilets and in the agri-food sector. Ideal for both manual washing with mop and rag, and for washing with scrubbers, with a lance or in recirculation systems.

Dilute the product in water according to directions, distribute it on the surfaces to be treated with a cloth, mop or scrubber. No rinsing required.

**Dosage:** 20-40 ml/L (2-4 caps every 5 litres) depending on the degree of soiling.

pH  
13 - 14

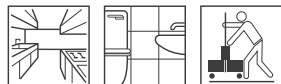

Code	1173	Pcs x Box	2
EAN	8054633831250	Box x Lyr	18
Volume	5 L / 5,8 kg	Box x Plt	72



View the data sheet on your smartphone.

## ACTIVE CHLOR GEL

Product pending registration as **Biocide**



Degreasing and whitening detergent with sodium hypochlorite for hard surfaces

- Cleans, deodorizes and removes stains in a single solution
- Whitening effect on grouting
- Degreases thoroughly and is also effective on pigmented dirt
- Easy to rinse
- It adheres to walls thanks to its gel formula

**Directions:** Dispense the product directly onto the surface to be cleaned, allow it to act for a few minutes and then wipe with a clean, damp cloth. Rinse thoroughly with water.

**Dosage:** Ready to use.

pH  
12,5 - 13,5



Code	1562-S	Pcs x Box	6
EAN	8032680399121	Box x Lyr	21
Volume	1000 ml	Box x Plt	105



View the data sheet on your smartphone.

# DEGREASERS AND SURFACE CLEANERS

## ACTIVE CHLOR TABLET



Active chlorine tablet sanitiser for cleaning washable surfaces and treating fruit and vegetable washing water

- Cleans, deodorizes and removes stains in a single solution
- Can be used to treat fruit and vegetable washing solutions
- Practical tablet format, easy to dose and avoids waste
- Each tablet releases 1500 ppm of active chlorine in one litre

**Directions:** As a surface cleaner: Dilute the product according to the recommended doses and apply it with a sponge, cloth or mop, then rinse with plenty of water. Treatment of aqueous solution for washing fruit and vegetables: Dilute the product according to the recommended doses, immerse fruit, vegetables and greens in the washing solution for 2-3 minutes, then rinse thoroughly with water.

**Dosage:** Surface cleaner: 2 tablets every 5 litres. Treatment of aqueous solution for washing fruit and vegetables: 1 tablet every 3 litres.

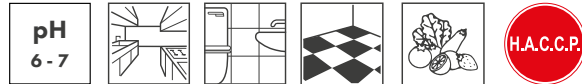

	Code	2122	Pcs x Box	12
	EAN	8054633838006	Box x Lyr	12
	Volume	150 Tabs	Box x Plt	72



## ACTIVE OXYGEN FOAM

Product pending registration as **Biocide**



Active oxygen-based whitening concentrate detergent for washing hard surfaces

- It guarantees deep cleaning on surfaces: it cleans and removes stains in a single solution
- Eliminates unpleasant odours

**Directions:** Dispense the product directly onto the surface to be cleaned, allow it to act for a few minutes and then wipe with a clean, damp cloth.

**Dosage:** Ready to use.



	Code	1175-5	Pcs x Box	6
	EAN	8054633838990	Box x Lyr	21
	Volume	750 ml	Box x Plt	105



## ACTIVE OXYGEN

Product pending registration as **Biocide**



Liquid detergent based on active oxygen for washing hard surfaces

- Easily removes dirt residues
- Cleans, deodorizes and removes stains in a single solution
- Eliminates unpleasant odours

**Directions:** Dilute the product in water according to directions, distribute it on the surfaces to be treated with a cloth, mop or scrubber. No rinsing required. Ideal for both mop and rag washing as well as spray cleaning.

**Dosage:** 20-40 ml/L (2-4 caps every 5 litres) depending on the degree of soiling.

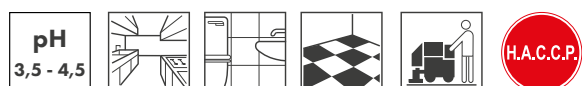

	Code	1174	Pcs x Box	2
	EAN	8054633831267	Box x Lyr	18
	Volume	5 L / 5,2 kg	Box x Plt	72



## SANIALC | Floral



Quick-drying universal cleaner with quaternary ammonium salts and alcohol for hard surfaces

- Cleans and degreases without needing to rinse
- Dries quickly without leaving streaks on surfaces
- Leaves the room pleasantly scented

**Directions:** Dispense the product directly onto the surface to be cleaned, allow it to act for a few minutes and then wipe with a clean, damp cloth.

**Dosage:** Ready to use.

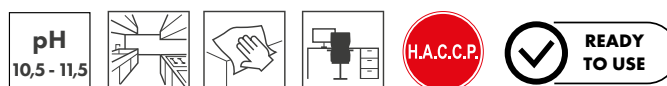

	Code	<b>1830-S</b>	Pcs x Box	6
	EAN	8032680391392	Box x Lyr	21
	Volume	750 ml	Box x Plt	105



## SANIALC ULTRA



Hydroalcoholic detergent for washing hard surfaces

- Cleans and sanitizes thoroughly without rinsing
- Dries quickly without leaving streaks on surfaces

**Directions:** Suitable for the treatment of all frequently touched surfaces that require a deep level of cleaning. Recommended for treating filters and ventilation ducts of air conditioning systems. Can be used on washable masks, natural fabrics, such as cotton, and synthetic fabrics such as polyester and non-woven fabrics. On hard surfaces: apply the product to the cloth or directly to the surface to be treated and then rub until dry. On fabrics: apply directly to the surface to be treated and let it evaporate.

**Dosage:** Ready to use.



	Code	<b>1841-S</b>	Pcs x Box	6
	EAN	8054633839126	Box x Lyr	21
	Volume	750 ml	Box x Plt	105



	Code	<b>1842</b>	Pcs x Box	2
	EAN	8054633839331	Box x Lyr	18
	Volume	5 L / 4,3 kg	Box x Plt	72



## FRYDET



Specific tablet detergent for cleaning professional fryers

- Quickly removes burnt oil and grease
- Leaves surfaces clean and shiny

**Directions:** Cleaning deep fryers: drain the oil and close the valve. Fill the tub with water until it reaches the oil level, add the detergent tablets in the recommended dose. Turn on the fryer and bring the solution to a boil, without exceeding 100°C. After cooling and emptying, remove any residue with an abrasive sponge or brush. Rinse thoroughly with water.

**Dosage:** 1 tablet for every 10 litres of water



	Code	<b>2131</b>	Pcs x Box	6
	EAN	8054633838549	Box x Lyr	16
	Volume	500 g	Box x Plt	160



# DEGREASERS AND SURFACE CLEANERS

## FORNONET



Super concentrated alkaline foaming detergent for ovens, grills and hobs

- Quickly removes caked-on grease, oil and charred food grime
- It forms a compact foam that adheres to vertical walls for greater effectiveness even in the most difficult to reach areas

**Code 1960-S\*** | **Directions:** Make sure the surface to be treated does not exceed 80°C (ideal 50°C - 60°C). Apply the product as is to the surfaces and leave on for a few moments. Remove any residue with an abrasive sponge or brush. Rinse thoroughly with water.

**Code 1961** | **Directions:** **Cleaning ovens, grills and hotplates:** make sure that the surface to be treated does not exceed 80°C (ideal 50°C - 60°C). Apply the product as is to the surfaces and leave on for a few moments. Remove any residue with an abrasive sponge or brush. Rinse thoroughly with water. **Cleaning deep fryers:** drain the oil and close the valve. Fill the tub with water until it reaches the oil level. For each litre of water add 50 - 100 ml of product (5 - 10 caps every 5 litres). Turn on the fryer and bring the solution to a boil, without exceeding 100°C. After cooling and emptying, remove any residue with an abrasive sponge or brush. Rinse thoroughly with water. **Cleaning the hood:** prepare a solution with 50 - 100 ml of product for each litre of water. Use warm water for greater effectiveness. Soak the previously dismantled hood pieces for 5-30 minutes. Rinse thoroughly with water.



Product to be used with the **foam lance** code **60** on p. 40



Code	<b>1960-S*</b>	Pcs x Box	6
EAN	8032680391811	Box x Lyr	21
Volume	750 ml	Box x Plt	105



View the data sheet on your smartphone.



Code	<b>1961</b>	Pcs x Box	2
EAN	8032680391576	Box x Lyr	18
Volume	5 L / 5,8 kg	Box x Plt	72



View the data sheet on your smartphone.

## SPRAY MAXI



Maxi foam spray with 120 cm extension for 5 L can

- Tidier room
- Increased safety for operators

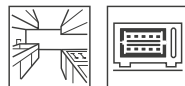

Code	<b>60</b>	Pcs x Box	1
EAN	-	Box x Lyr	-
Volume	-	Box x Plt	-

## OVEN POWER



Non-foaming concentrated alkaline detergent for self-cleaning ovens

- Effectively removes cooking residues and charred dirt
- Safe on surfaces to be cleaned
- Effective even in the most difficult to reach places

**Directions:** Always follow the oven manufacturer's instructions as indicated in the oven's user manual. Insert the product into the appropriate detergent tray, the product is then automatically dosed into the oven. The dosage level is determined by the washing program set by the oven.

**Dosage:** Ready to use.



Code	<b>1965</b>	Pcs x Box	2
EAN	8032680392849	Box x Lyr	18
Volume	5 L / 6,5 kg	Box x Plt	72



View the data sheet on your smartphone.

## BRILL OVEN



Concentrated acid brightening agent for self-cleaning ovens

- Leaves surfaces shiny
- Prevents the formation of streaks
- Quick drying
- Removes limescale
- Neutralizes any detergent residue after the washing process

**Directions:** Always follow the oven manufacturer's instructions as indicated in the oven's user manual. Insert the dipstick into the tank or the product into the appropriate tray, the product is then automatically dosed into the oven. The dosage level is determined by the washing program set by the oven.

**Dosage:** Ready to use.



Code	<b>1967</b>	Pcs x Box	2
EAN	8032680392832	Box x Lyr	18
Volume	5 L / 5,1 kg	Box x Plt	72



View the data sheet on your smartphone.

## CAFFÈ WASH



Concentrated alkaline detergent for interior cleaning of professional coffee machines

- Quickly removes carbonized dirt in filters and arms of coffee machines
- Eliminates bad odours
- Keeps the aroma of the coffee unchanged

**How to use and dosage:** For use in the blind filter to clean filters and arms, dose 20 ml of product for each litre of warm water (2 caps for every 5 litres). For soaking use, dose 40 to 50 ml for every litre of warm water (4-5 caps for every 5 litres).

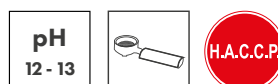

Code	<b>2161</b>	Pcs x Box	6
EAN	8050999572172	Box x Lyr	21
Volume	900 ml	Box x Plt	105



View the data sheet on your smartphone.

# DEGREASERS AND SURFACE CLEANERS

## INDUCTION HOBS



Specific detergent for cleaning glass ceramic and induction hobs

- Effectively and quickly removes greasy dirt and charred food residues
- Leaves surfaces clean and shiny
- Effective even in the most difficult to reach places

**Directions:** Dispense the product directly onto the surface to be cleaned, allow it to act for a few minutes and then wipe with a clean, damp cloth.

**Dosage:** Ready to use.



Code	1836	Pcs x Box	6
EAN	8054633837061	Box x Lyr	21
Volume	500 ml	Box x Plt	105



View the data sheet on your smartphone.

## STEEL PRO



Ready-to-use maintenance polish for steel surfaces

- Effectively removes dirt, grease, fingerprints and other types of dirt that adhere to surfaces
- Polishes and protects all steel surfaces
- Forms a protective layer that delays the formation of stains and limescale

**Directions:** Dispense the product directly onto the surface to be cleaned and rub until completely dry.

**Dosage:** Ready to use.



Code	1813	Pcs x Box	6
EAN	8054633830598	Box x Lyr	21
Volume	500 ml	Box x Plt	105



View the data sheet on your smartphone.

## GREKOL SS



Concentrated alkaline, unscented degreasing detergent suitable for cleaning aluminium, copper, silver and brass surfaces.

- Effectively and quickly removes even stubborn dirt
- Unscented product, suitable for cleaning all surfaces and kitchen equipment
- Compatible with all surfaces including marble and soft metals such as aluminium and copper

**Directions:** Dilute the product in water according to the instructions, spread it on the surfaces to be treated and leave it on for a few minutes. Scrub to remove stubborn build-up, then rinse with plenty of water.

**Dosage:** 20-50 ml/L (2-5 caps every 5 litres) depending on the degree of dirt.

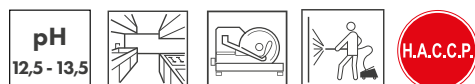

Code	1815	Pcs x Box	2
EAN	8032680392740	Box x Lyr	18
Volume	5 L / 5,4 kg	Box x Plt	72



View the data sheet on your smartphone.

## SILVER



Degreasing and deoxidizing detergent for cleaning silver, aluminium, copper and brass surfaces

- Quickly removes black oxidation stains from silver, through immersion only, no scrubbing required
- Leaves surfaces shiny

**Directions:** Dispense the product directly onto the surface to be cleaned, allow it to act for a few minutes and then wipe with a clean, damp cloth. Soaking: Pour the undiluted product into a bowl of water, then completely immerse the objects for a few minutes. When necessary, use a cloth or brush directly on the oxidation/dirt stains, then rinse and dry.

**Dosage:** 20-50 ml/L



Code	1881	Pcs x Box	2
EAN	8032680391484	Box x Lyr	18
Volume	5 L / 5,2 kg	Box x Plt	72



View the data sheet on your smartphone.

## INOX



Specific degreasing detergent for steel surfaces

- Effectively removes greasy dirt, food residues and stubborn grime
- Makes surfaces shiny
- Leaves a protective layer on the treated surface
- Suitable for all metal surfaces such as stainless steel, copper, aluminium and brass

**Directions:** Dispense the product directly onto the surface to be cleaned, allow it to act for a few minutes and then wipe with a clean, damp cloth. Rinse thoroughly with water.

**Dosage:** Ready to use.



Code	1875-5	Pcs x Box	6
EAN	8032680392115	Box x Lyr	21
Volume	750 ml	Box x Plt	105



View the data sheet on your smartphone.

## NATURAL



Liquid detergent for treating fruit and vegetable washing water based on sodium bicarbonate

- Neutral product with sodium bicarbonate to facilitate the cleaning of fruit and vegetables
- It does not affect the taste of vegetables and greens
- Recommended in the private, school and hospital catering sectors
- It does not contain chlorine

**Directions:** By soaking them manually or using automatic vegetable washers. Soak fruit, vegetables and greens in the washing solution for 2-3 minutes, then rinse thoroughly with water.

**Dosage:** 10-30 ml/L (1-3 caps every 5 litres).



Code	2100	Pcs x Box	2
EAN	8032680391705	Box x Lyr	18
Volume	5 L / 5,1 kg	Box x Plt	72



View the data sheet on your smartphone.





# Floors



# Professional care, protection and hygiene

The Sanitec flooring range offers professional solutions for every type of surface and level of traffic, from high-traffic floors to the most delicate ones, tackling any degree of soiling and meeting the demands of sanitisation and disinfection. In addition to detergents, the line includes specific products for surface protection and air fresheners enriched with odour-eliminating technology to ensure not only hygiene, but also a pleasant sensory experience.

Ecolabel-certified products are also in the range, to combine professional effectiveness with certified environmental sustainability.

## TECHNICAL PERFORMANCE

PRODUCTS	DAILY CLEANING	INTENSIVE CLEANING	INTENSE FRAGRANCE	SHINING SURFACES	DESCALER	DISINFECTANT	SANITIZING	SURFACE PROTECTION	WAX REMOVER
<b>IGIENIC FLOOR</b> Code 1435, 1410, 1436, 1437, 1439, 1433-S, 1434-S	●								
<b>NEUTRO FLOOR</b> Code 1481-S, 1480	●								
<b>BRILL LUX</b> Code 1415	●			●					
<b>SIRPAV</b> Code 1421-S		●							
<b>SIRPAV HC</b> Code 1422		●							
<b>MATIC FLOOR</b> Code 1440		●							
<b>MATIC EXTRA</b> Code 1445		●							
<b>FLOOR ACID</b> Code 1460		●			●				
<b>PULI ACID</b> Code 1491		●			●				
<b>MOQUETTE</b> Code 1450		●							
<b>PARQUET</b> Code 1470,1471-S	●								
<b>DEO SURFACE</b> Code 2200, 2201, 2202, 2204, 2203, 2205	●		●						
<b>SURFACE GREEN POWER</b> Code 3109-S, 3105	●								
<b>SANIMED</b> Code 1511	●					●			
<b>BAKTERIO</b> Code 1541, 1544, 1540-S	●					●			
<b>ACTIVE CHLOR</b> Code 1173	●						●		
<b>ACTIVE OXYGEN</b> Code 1174	●						●		
<b>SANIALC ULTRA</b> Code 1841-S, 1842	●			●			●		
<b>SANIALC</b> Code 1425, 1426N-S	●			●			●		
<b>SANIFORM</b> Code 1521	●						●		
<b>WX1 METALIZED WAX</b> Code 1610								●	
<b>WX3 WAX &amp; CLEAN</b> Code 1640	●							●	
<b>WX2 WAX REMOVER</b> Code 1660									●

## A solution for every type of surface

Sanitec floor cleaners are formulated to meet the needs of different surface types, ensuring effective cleaning without compromising the materials. Thanks to specific solutions for the degree of porosity, finish and sensitivity of the substrate, Sanitec cleaners ensure a high cleaning performance even on the most stubborn dirt, while at the same time facilitating surface care and protection.

The cleaning action is balanced to respect treatments (e.g. waxes, protective films) and reduce the risk of dulling or streaking, improving the appearance of the floor, wash after wash. The result is a cleaner, safer and more enhanced environment with products designed for everyday and professional use.

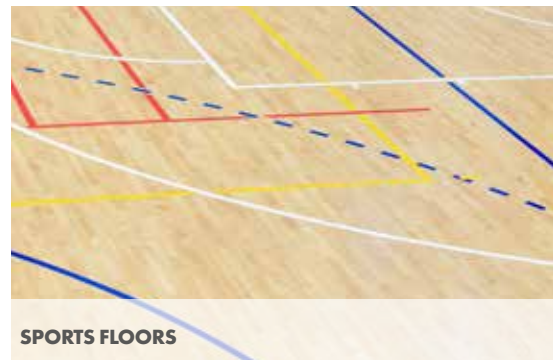
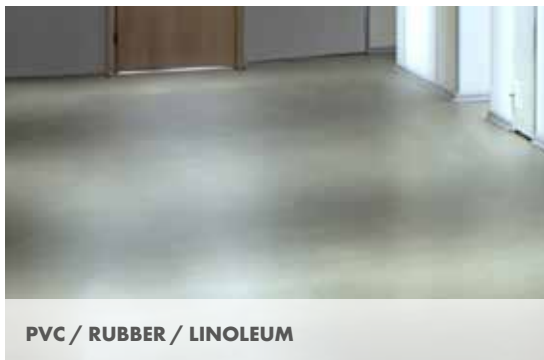

## SURFACE TYPES

PRODUCTS	PVC / RUBBER / LINOLEUM	PARQUET (sealed, unsealed, laminated)	SPORTS FLOORS	MARBLE	GRANITE	HARD STONE	STONE / SOFT STONE / CONCRETE TERRACE	CERAMICS AND PORCELAIN STONEWARE	CLINKER	TERRACOTTA	CEMENT SLABS	CARPET
<b>IGIENIC FLOOR</b> Code 1435, 1410, 1436, 1437, 1439, 1433-S, 1434-S	●	●	●	●	●	●	●	●	●	●	●	
<b>NEUTRO FLOOR</b> Code 1481-S, 1480	●	●	●	●	●	●	●	●	●	●	●	
<b>BRILL LUX</b> Code 1415	●	●	●	●	●	●	●	●	●	●	●	
<b>SIRPAV</b> Code 1421-S	●	●	●	●	●	●	●	●	●	●	●	
<b>SIRPAV HC</b> Code 1422	●	●	●	●	●	●	●	●	●	●	●	
<b>MATIC FLOOR</b> Code 1440				●	●	●	●	●	●	●	●	
<b>MATIC EXTRA</b> Code 1445				●	●	●	●	●	●	●	●	
<b>FLOOR ACID</b> Code 1460								●				
<b>PULI ACID</b> Code 1491								●				
<b>MOQUETTE</b> Code 1450												●
<b>PARQUET</b> Code 1470,1471-S		●										
<b>DEO SURFACE</b> Code 2200, 2201, 2202, 2204, 2203, 2205	●	●	●	●	●	●	●	●	●	●	●	
<b>SURFACE GREEN POWER</b> Code 3109-S, 3105	●	●	●	●	●	●	●	●	●	●	●	
<b>SANIMED</b> Code 1511	●	●	●	●	●	●	●	●	●	●	●	
<b>BAKTERIO</b> Code 1541, 1544, 1540-S	●	●	●	●	●	●	●	●	●	●	●	
<b>ACTIVE CHLOR</b> Code 1173			●	●	●		●	●		●		
<b>ACTIVE OXYGEN</b> Code 1174			●	●	●		●	●		●		
<b>SANIALC ULTRA</b> Code 1841-S, 1842			●	●	●	●	●	●	●	●		
<b>SANIALC</b> Code 1425, 1426N-S	●	●	●	●	●	●	●	●	●	●	●	
<b>SANIFORM</b> Code 1521	●	●	●	●	●	●	●	●	●	●	●	
<b>WX1 METALIZED WAX</b> Code 1610	●			●		●		●	●			
<b>WX3 WAX &amp; CLEAN</b> Code 1640		●										
<b>WX2 WAX REMOVER</b> Code 1660								●				

# ODOUR NEUTRALIZING DETERGENTS

## DEO SURFACE

Multi-surface cleaner for floors and other hard surfaces, with odour-eliminating technology

- Cleans thoroughly
- Persistent fragrance up to **24h**
- Leaves surfaces shining, without streaks

**Directions:** Dilute the product in water according to the directions. Apply the product diluted with a cloth, mop or scrubber. No rinsing required.

### Dosage:

Mop/scrubber cleaning:

For routine cleaning dilute the product to 1% (10 ml/L)

For a medium degree of soiling dilute the product to 2% (20 ml/L)

For stubborn soiling and for extra fragrance dilute the product to 3% (30 ml/L)

### Cleaning with spray:

For routine cleaning dilute the product to 1% (10 ml/L)

For a medium degree of soiling dilute the product to 2% (20 ml/L)

Dosing cap capacity: 50 ml (without safety seal). Apply the product diluted with a cloth, mop or scrubber. No rinsing required. Add a capful of detergent for an even more intense fragrance.



**White Musk**

Code	<b>2200</b>
EAN	8050999572868
Pack	2 pcs x 5 L / 5 kg
Box x Lyr	18
Box x Plt	72



View the data sheet



**Gold argan**

Code	<b>2201</b>
EAN	8050999572875
Pack	2 pcs x 5 L / 5 kg
Box x Lyr	18
Box x Plt	72



View the data sheet

# ODOUR NEUTRALIZING DETERGENTS



## Fresh citrus

Code **2202**  
 EAN 8050999572882  
 Pack 2 pcs x 5 L / 5 kg  
 Box x Lyr 18  
 Box x Plt 72



View the data sheet



## Pine & juniper

Code **2203**  
 EAN 8050999572899  
 Pack 2 pcs x 5 L / 5 kg  
 Box x Lyr 18  
 Box x Plt 72



View the data sheet



## Flower bouquet

Code **2204**  
 EAN 8050999572905  
 Pack 2 pcs x 5 L / 5 kg  
 Box x Lyr 18  
 Box x Plt 72



View the data sheet



## Peach & green apple

Code **2205**  
 EAN 8050999572912  
 Pack 2 pcs x 5 L / 5 kg  
 Box x Lyr 18  
 Box x Plt 72



View the data sheet

## SURFACE GREEN POWER | Floral



Universal detergent, **Ecolabel-certified**, for floors and hard surfaces

- EU Ecolabel-certified product with low environmental impact
- Excellent degreasing power, removes all types of dirt
- Does not require rinsing and leaves no streaks
- Controlled foam can be used with mop method or with scrubbers

**Directions:** Ideal for all types of water-resistant washable floors. **Small surfaces/stubborn dirt:** Apply the product as is directly to the surface to be cleaned, leave on for a few minutes and then rub with a clean, damp cloth. Rinse with water. **Large surfaces/ordinary cleaning:** Dilute the product in water, apply the product to the surface to be washed with a mop or cloth. No rinsing required.

**Dosage:** 10-30 ml/L (Code 3109-S: 2-6 caps every 5 litres, Code 3105: 1-3 caps every 5 litres) depending on the degree of dirt.



Code	<b>3109-S</b>	Pcs x Box	6
EAN	8054633837085	Box x Lyr	21
Volume	1000 ml	Box x Plt	105



View the data sheet on your smartphone.



Code	<b>3105</b>	Pcs x Box	2
EAN	8032680393679	Box x Lyr	18
Volume	5 L / 5.1 kg	Box x Plt	72



View the data sheet on your smartphone.

## IGIENIC FLOOR

Universal cleaner for floors and all hard surfaces

- Slightly alkaline concentrated product with excellent degreasing power, removes all types of dirt
- No rinsing required
- Leaves no streaking
- Thanks to its fragrance, it leaves a pleasant scent in the room
- Controlled foam can be used with mop method or with scrubbers

**Directions:** Ideal for all types of water-resistant washable floors. Dilute the product in water according to directions, distribute it on the surfaces to be treated with a cloth, mop or scrubber. No rinsing required.

**Dosage:** 20-40 ml/L (2-4 caps per 5 litres) depending on the degree of soiling.

**pH**  
10,5 - 11,5

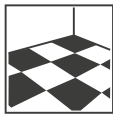

### Orange blossom

Code **1433-S**  
EAN 8032680399541  
Pack 6 pcs x 1000 ml  
Box x Lyr 21  
Box x Plt 105



View the data sheet



### Green apple

Code **1434-S**  
EAN 8032680397592  
Pack 6 pcs x 1000 ml  
Box x Lyr 21  
Box x Plt 105



View the data sheet



### Orange blossom

Code **1435**  
EAN 8032680391156  
Pack 2 pcs x 5 L / 5 kg  
Box x Lyr 18  
Box x Plt 72



View the data sheet



### Green apple

Code **1437**  
EAN 8032680393235  
Pack 2 pcs x 5 L / 5 kg  
Box x Lyr 18  
Box x Plt 72



View the data sheet



**Lavender**

Code **1436**  
 EAN 8032680392085  
 Pack 2 pcs x 5 L / 5 kg  
 Box x Lyr 18  
 Box x Plt 72



View the data sheet



**Mint and lemon**

Code **1410**  
 EAN 8032680391149  
 Pack 2 pcs x 5 L / 5 kg  
 Box x Lyr 18  
 Box x Plt 72



View the data sheet



**Peach**

Code **1439**  
 EAN 8032680393556  
 Pack 2 pcs x 5 L / 5 kg  
 Box x Lyr 18  
 Box x Plt 72



View the data sheet

**NEUTRO FLOOR | Floral**



Neutral cleaner for delicate and wax-protected floors

- Effectively removes dirt
- It does not attack the wax, it does not dull the surfaces leaving the floors in their original state
- Leaves a pleasant scent in the room
- Does not require rinsing and leaves no streaks

**Directions:** Ideal for all types of water-resistant and delicate washable floors such as marble, Venetian terrazzo, Palladiana and parquet. Dilute the product in water according to the instructions and spread it on the surfaces to be treated. Scrub to remove stubborn build-up. No rinsing required.

**Dosage:** 20-40 ml/L (2-4 caps every 5 litres) depending on the degree of soiling.

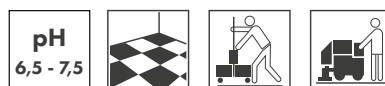

	Code <b>1481-S</b>	Pcs x Box	6
	EAN 8054633838020	Box x Lyr	21
	Volume 1000 ml	Box x Plt	105



View the data sheet on your smartphone.

	Code <b>1480</b>	Pcs x Box	2
	EAN 8032680391194	Box x Lyr	18
	Volume 5 L / 5 kg	Box x Plt	72



View the data sheet on your smartphone.

# DETERGENTS

## MATIC FLOOR



Universal non-foaming alkaline cleaner for hard surfaces

- Removes stubborn dirt from high-traffic floors
- Does not require rinsing and leaves no streaks
- Non-foaming, can be used with mop method or with floor scrubbers

**Directions:** Ideal for use with the mop method or with scrubbers. Dilute the product in water according to directions, distribute it on the surfaces to be treated with a cloth, mop or scrubber. No rinsing required.

**Dosage:** 20-40 ml/L (2-4 caps every 5 litres) depending on the degree of dirt

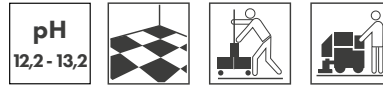

Code	1440	Pcs x Box	2
EAN	8032680391187	Box x Lyr	18
Volume	5 L / 5,6 kg	Box x Plt	72



View the data sheet on your smartphone.

## MATIC EXTRA



Non-foaming alkaline heavy-duty cleaner for hard surfaces

- Effectively removes the most stubborn dirt from high traffic floors in public and industrial environments
- Removes black marks left by forklift tires and wheels
- Does not require rinsing and leaves no streaks
- Non-foaming, can be used with mop method or with floor scrubbers

**Directions:** Ideal for use with the mop method or with scrubbers. Dilute the product in water according to directions, distribute it on the surfaces to be treated with a cloth, mop or scrubber. No rinsing required.

**Dosage:** 20-40 ml/L (2-4 caps every 5 litres) depending on the degree of dirt

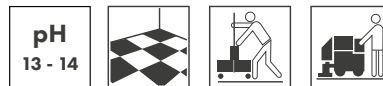

Code	1445	Pcs x Box	2
EAN	8032680395895	Box x Lyr	18
Volume	5 L / 6,5 kg	Box x Plt	72



View the data sheet on your smartphone.

## SIRPAV | Pine



Ammonia-based universal degreasing detergent with controlled foam for floors and hard surfaces

- Slightly alkaline product with ammonia with degreasing power
- Eliminates bad odours and leaves the room pleasantly scented
- Does not require rinsing and leaves no streaks
- With controlled foam, it can be used with the mop method or with scrubbers

**Directions:** Ideal for cleaning floors with a high level of dirt, such as in kitchens, food laboratories, factories, warehouses, etc. Dilute the product in water according to the instructions, distribute it on the surfaces to be treated with a cloth, mop or floor scrubber. No rinsing required.

**Dosage:** 10-30 ml/L (1-3 caps every 5 litres) depending on the degree of dirt



Code	1421-S	Pcs x Box	6
EAN	8032680392337	Box x Lyr	21
Volume	1000 ml	Box x Plt	105



View the data sheet on your smartphone.

SIRPAV HC | Pine





Concentrated, universal, controlled-foam ammonia-based degreasing detergent for floors and hard surfaces.

- Concentrated product slightly alkaline with ammonia with excellent power degreaser, removes all types of dirt
- Eliminates bad odours and leaves the room pleasantly scented
- Does not require rinsing and leaves no streaks
- With controlled foam, it can be used with the mop method or with scrubbers

**Directions:** Ideal for use with the mop method or with scrubbers. Dilute the product in water according to directions, distribute it on the surfaces to be treated with a cloth, mop or scrubber. No rinsing required.

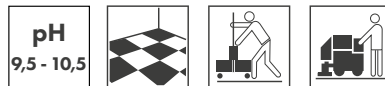
**Dosage:** 3-10 ml/L (0.3-1 capfuls every 5 litres) depending on the degree of dirt



	Code	1422	Pcs x Box	2
	EAN	8032680392818	Box x Lyr	18
	Volume	5 L / 5,3 kg	Box x Plt	72



PULI ACID | Citrus





Concentrated descaling detergent with phosphoric acid for removing persistent incrustations from floors and hard surfaces

- Quickly and effectively removes inorganic encrustations such as limescale, cement residues, rust stains from acid-resistant surfaces
- Eliminates bad odours and leaves a pleasant scent in the room
- Safe on surfaces to be descaled

**Directions:** Dilute the product in water according to the instructions, spread it on the surfaces to be treated and leave it on for a few minutes. Scrub to remove stubborn build-up, then rinse with plenty of water.

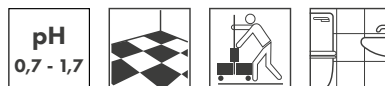
**Dosage:** Ordinary cleaning: 10-20 ml/L depending on the degree of dirt. Stubborn dirt: 40/50 ml/L



	Code	1491	Pcs x Box	6
	EAN	8054633838044	Box x Lyr	21
	Volume	1000 ml	Box x Plt	105

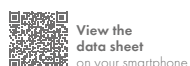

FLOOR ACID





Hydrochloric acid-based descaling detergent for heavy soiling and first-time use

- Effectively removes inorganic incrustations such as: lime deposits, efflorescence from saltpetre, cement, plaster, rust
- Ideal for the thorough cleaning of newly laid floors, such as Florentine terracotta, stoneware and clinker

**Directions:** Dilute the product in water according to the instructions, spread it on the surfaces to be treated and leave it on for a few minutes. Scrub to remove stubborn build-up, then rinse with plenty of water.

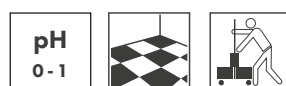
**Dosage:** 3-10 ml/L (0.3-1 capfuls every 5 litres) depending on the degree of dirt



	Code	1460	Pcs x Box	2
	EAN	8032680391200	Box x Lyr	18
	Volume	5 L / 5,5 kg	Box x Plt	72

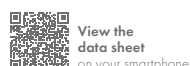

## ACTIVE CHLOR

Product pending registration as **Biocide**



Concentrated liquid detergent based on non-foaming sodium hypochlorite for hard surfaces

- Cleans, deodorizes and removes stains in a single solution
- Effectively removes stubborn dirt
- Eliminates unpleasant odours
- Easy rinsing thanks to its non-foaming formula

**Directions:** Ideal for places open to the public such as hospitals, schools, hotels, changing rooms, toilets and in the agri-food sector. Ideal for both manual washing with mop and rag, and for washing with scrubbers, with a lance or in recirculation systems.

Dilute the product in water according to directions, distribute it on the surfaces to be treated with a cloth, mop or scrubber. No rinsing required.

**Dosage:** 20-40 ml/L (2-4 caps every 5 litres) depending on the degree of soiling.



Code	1173	Pcs x Box	2
EAN	8054633831250	Box x Lyr	18
Volume	5 L / 5,8 kg	Box x Plt	72



View the data sheet on your smartphone.

## ACTIVE CHLOR TABLET

Active chlorine tablet sanitiser for cleaning washable surfaces and treating fruit and vegetable washing water

- Cleans, deodorizes and removes stains in a single solution
- Can be used to treat fruit and vegetable washing solutions
- Practical tablet format, easy to dose and avoids waste
- Each tablet releases 1500 ppm of active chlorine in one litre

**Directions:** As a surface cleaner: Dilute the product according to the recommended doses and apply it with a sponge, cloth or mop, then rinse with plenty of water. Treatment of aqueous solution for washing fruit and vegetables: Dilute the product according to the recommended doses, immerse fruit, vegetables and greens in the washing solution for 2-3 minutes, then rinse thoroughly with water.

**Dosage:** Surface cleaner: 2 tablets every 5 litres. Treatment of aqueous solution for washing fruit and vegetables: 1 tablet every 3 litres.



Code	2122	Pcs x Box	12
EAN	8054633838006	Box x Lyr	12
Volume	150 Tabs	Box x Plt	72



View the data sheet on your smartphone.

## ACTIVE OXYGEN

Product pending registration as **Biocide**



Liquid detergent based on active oxygen for washing hard surfaces

- Easily removes dirt residues
- Cleans, deodorizes and removes stains in a single solution
- Eliminates unpleasant odours

**Directions:** Dilute the product in water according to directions, distribute it on the surfaces to be treated with a cloth, mop or scrubber. No rinsing required. Ideal for both mop and rag washing as well as spray cleaning.

**Dosage:** 20-40 ml/L (2-4 caps every 5 litres) depending on the degree of soiling.



Code	1174	Pcs x Box	2
EAN	8054633831267	Box x Lyr	18
Volume	5 L / 5,2 kg	Box x Plt	72



View the data sheet on your smartphone.

**SANIFORM** | Balsamic Pine



Scented sanitising detergent with quaternary ammonium salts for washing hard surfaces and floors

- Removes any trace of dirt from all washable surfaces
- Does not require rinsing and leaves no streaks
- Leaves a pleasant scent in the room

**Directions:** Dilute the product in water according to directions, distribute it on the surfaces to be treated with a cloth or mop. No rinsing required.

**Dosage:** 20-30 ml/L (2-3 caps every 5 litres) depending on the degree of dirt.

pH  
10 - 11



Code	<b>1520N-S</b>	Pcs x Box	6
EAN	8032680390289	Box x Lyr	21
Volume	1000 ml	Box x Plt	105



View the data sheet on your smartphone.



Code	<b>1521</b>	Pcs x Box	2
EAN	8032680391255	Box x Lyr	18
Volume	5 L / 5 kg	Box x Plt	72



View the data sheet on your smartphone.

**SANIALC**



Quick-drying alcohol-based cleaner for floors and hard surfaces

- Removes all types of dirt
- Quick drying and leaves no streaks
- No rinsing required
- Eliminates bad odours and leaves a pleasant scent in the room

**Directions:** Ideal for all types of water-resistant washable floors. Dilute the product in water according to directions, distribute it on the surfaces to be treated with a cloth or mop. No rinsing required.

**Dosage:** 10-30 ml/L (1-3 caps every 5 litres) depending on the degree of dirt.

pH  
7,5 - 8,5



Code	<b>1426N-S</b>	Pcs x Box	6
EAN	8032680392276	Box x Lyr	21
Volume	1000 ml	Box x Plt	105



View the data sheet on your smartphone.



Code	<b>1425</b>	Pcs x Box	2
EAN	8032680391170	Box x Lyr	18
Volume	5 L / 5 kg	Box x Plt	72



View the data sheet on your smartphone.

**PROMAX DILUTER**



Automatic dispenser connected to the water mains capable of quickly and easily preparing any product dilution to be used in common cleaning applications

- Code **90** for the dosage of one bottle;
- Code **18** for the dosage of one bucket;
- Code **91** for dosing four types of bottles with different liquids;
- Code **68** for dosing four types of bucket with different liquids.

Code	<b>90</b>
EAN	-
Pcs x Box	1

Code	<b>18</b>
EAN	8032680395444
Pcs x Box	1

Code	<b>91</b>
EAN	-
Pcs x Box	1

Code	<b>68</b>
EAN	8054633831281
Pcs x Box	1

**SANIMED | Unscented**



Concentrated disinfectant for surfaces according to **Italian Ministry of Health**, Registration no. 20047

- Eliminates 99.9% of bacteria, fungi and viruses
- Fungicidal, bactericidal and virucidal action, active against gram-positive and gram-negative bacteria, fungi, moulds and viruses, both enveloped and non-enveloped, present in domestic and professional environments
- Particularly suitable for disinfecting surfaces and equipment in the agri-food, hotel and catering industries
- It is also suitable for use in high traffic environments, such as bathrooms in public places, outpatient clinics and hospital environments

**Directions:** Dilute SANIMED® in water and spray or spread with a sponge or mop. For small utensils, immerse the material to be disinfected. When disinfecting surfaces that may come into direct contact with food, rinse with potable water. For virucidal action, apply the product to the previously cleaned surface, in a 5% solution equal to 250 ml per 5 litres of water.

**Dosage:** For normal cleaning dilute SANIMED® at 0.5%, equal to 25 ml per 5 litres of water. For disinfection, dilute SANIMED® at 1.5%, equal to 75 ml per 5 litres of water and leave to act for at least 5 minutes for bactericidal activity or at least 15 minutes for fungicidal and virucidal activity.



Code	<b>1511</b>	Pcs x Box	2
EAN	8032680391248	Box x Lyr	18
Volume	5 L / 5 kg	Box x Plt	72



View the data sheet on your smartphone.

**Active ingredient**

Alkyl dimethylbenzyl ammonium chloride 10 g/100 g



**Product code** 1511

**Active ingredient** Alkyl dimethylbenzyl ammonium chloride 10 g/100 g

	<b>Bactericidal efficacy</b>	<b>Fungicidal efficacy</b>	<b>Virucidal efficacy</b>
<b>Regulation</b>	UNI EN 1276:2009 UNI EN 13697:2015	UNI EN 1650:2008 UNI EN 13697:2001	UNI EN 14476:2019 UNI EN 16777:2019
<b>Tested organisms</b>	Pseudomonas aeruginosa Staphylococcus aureus Enterococcus hirae Escherichia coli	Candida albicans Penicillium verrucosum	Vaccinia virus Adenovirus type 5, Murine norovirus MNV
<b>Conditions of use</b>	Concentration: 1,5% Contact time: 5 minutes Dirt conditions	Concentration: 1,5% Contact time: 15 minutes Dirt conditions	Concentration: 5% Contact time: 15 minutes Clean conditions

**BAKTERIO** | Balsamic pine



Concentrated disinfectant for surfaces according to **Italian Ministry of Health**, Registration no. 15446.

- Disinfects, cleans and deodorizes
- Removes all traces of dirt and eliminates bad odours
- It leaves a pleasant scent
- Safe on metals, does not stain surfaces

**Directions:** BAKTERIO® should be used with a cloth or sponge soaked in the solution to disinfect, clean and deodorise rooms and objects in hotels, canteens, industries, schools, retirement homes, etc.

**Dosage:** To disinfect and deodorize bathrooms, sinks, walls, floors, tiles, waste containers, toilet bowls and other surfaces, potential sources of germs, dilute BAKTERIO® in water at a ratio of 20%, leaving it on for 15 minutes. For ordinary disinfection and cleaning of bathrooms, sinks, walls, floors, tiles, doors, doorposts and other washable surfaces, dilute BAKTERIO® in water from 1 to 3% leaving it on for 5 minutes.



**Active ingredient**

Alkyl dimethylbenzyl ammonium chloride 3 g/100 g

	Code	<b>1540N-S</b>	Pcs x Box	6
	EAN	8032680392719	Box x Lyr	21
	Volume	1000 ml	Box x Plt	105



	Code	<b>1541</b>	Pcs x Box	2
	EAN	8032680392726	Box x Lyr	18
	Volume	5 L / 5 kg	Box x Plt	72



**BAKTERIO** | Lime



Concentrated disinfectant for surfaces according to **Italian Ministry of Health**, Registration no. 15446.

- Disinfects, cleans and deodorizes
- Removes all traces of dirt and eliminates bad odours
- It leaves a pleasant scent
- Safe on metals, does not stain surfaces

**Directions:** BAKTERIO® should be used with a cloth or sponge soaked in the solution to disinfect, clean and deodorise rooms and objects in hotels, canteens, industries, schools, retirement homes, etc.

**Dosage:** To disinfect and deodorize bathrooms, sinks, walls, floors, tiles, waste containers, toilet bowls and other surfaces, potential sources of germs, dilute BAKTERIO® in water at a ratio of 20%, leaving it on for 15 minutes. For ordinary disinfection and cleaning of bathrooms, sinks, walls, floors, tiles, doors, doorposts and other washable surfaces, dilute BAKTERIO® in water from 1 to 3% leaving it on for 5 minutes.



**Active ingredient**

Alkyl dimethylbenzyl ammonium chloride 3 g/100 g

	Code	<b>1544</b>	Pcs x Box	2
	EAN	8032680393921	Box x Lyr	18
	Volume	5 L / 5 kg	Box x Plt	72



**Product code** 1540N-S, 1541, 1544, 1713

**Active ingredient** Alkyl dimethylbenzyl ammonium chloride 3 g/100 g

**Bactericidal efficacy**

**Fungicidal efficacy**

**Virucidal efficacy**

**Regulation**

UNI EN 1276:2009  
UNI EN 13697:2001

UNI EN 1650:2008  
UNI EN 13697:2001

UNI EN 14476:2019  
UNI EN 16777:2019

**Tested organisms**

Pseudomonas aeruginosa  
Staphylococcus aureus  
Enterococcus hirae  
Escherichia coli

Candida albicans  
Penicillium verrucosum

Vaccinia virus  
Adenovirus type 5,  
Murine norovirus MNV

**Conditions of use**

Concentration: 5%  
Contact time: 5 minutes  
Dirt conditions

Concentration: 5%  
Contact time: 15 minutes  
Dirt conditions

Concentration: 20%  
Contact time: 15 minutes  
Clean conditions

## OTHER SURFACES

### PARQUET | Floral



Gentle neutral detergent with natural wax for hard wooden surfaces

- Protects, nourishes and gives shine to floors
- Leaves a pleasant scent in the room
- Neutral product with natural wax for the daily cleaning of wooden floors

**Directions:** Dilute the product in water according to the instructions and spread it on the surfaces to be treated. Scrub to remove stubborn build-up. No rinsing required.

**Dosage:** 10-20 ml/L (1-2 caps every 5 litres) depending on the degree of dirt.



Code	1471-5	Pcs x Box	6
EAN	8054633838037	Box x Lyr	21
Volume	1000 ml	Box x Plt	105



View the data sheet on your smartphone.



Code	1470	Pcs x Box	2
EAN	8032680391217	Box x Lyr	18
Volume	5 L / 5,1 kg	Box x Plt	72



View the data sheet on your smartphone.

### MOQUETTE



Concentrated alkaline detergent for carpets, rugs and fabrics

- Removes dirt thoroughly and effectively
- Leaves the room pleasantly scented
- Preserves the colours and structure of fabrics

**Directions:** For use with injection/extraction machines. Vacuum the carpet. Spray the product solution on the surface to be cleaned. Leave on for a few minutes. Use the injection/extraction machine only with water in the solution tank, and pass the lance in the opposite direction to the direction of the pile.

**Dosage:** 10-30 ml/L (1-3 caps every 5 litres) depending on the degree of dirt.



Code	1450	Pcs x Box	2
EAN	8032680391224	Box x Lyr	18
Volume	5 L / 5,2 kg	Box x Plt	72



View the data sheet on your smartphone.

### BRILL LUX | Citrus



Solvent-based degreasing detergent with a polishing effect for hard surfaces

- Leaves surfaces shiny and pleasantly scented
- Excellent degreasing power, removes all types of dirt
- Does not require rinsing and leaves no streaks

**Directions:** Dilute the product in water according to directions, distribute it on the surfaces to be treated with a cloth, mop or scrubber. No rinsing required.

**Dosage:** 10-20 ml/L (1-2 caps every 5 litres) depending on the degree of dirt.



Code	1415	Pcs x Box	2
EAN	8032680392108	Box x Lyr	18
Volume	5 L / 5 kg	Box x Plt	72



View the data sheet on your smartphone.

**WX1 METALIZED WAX** | Citrus



Self-polishing metallic wax with high cross-linking, suitable for heavy traffic environments

- Self-polishing emulsion with high gloss suitable for all types of floors
- The protective film has a high resistance to traffic, has anti-slip properties and a dirt-repellent effect
- Leaves a pleasant scent in the room
- Quick drying. Easy to use

**Directions:** Only treat carefully dewaxed, well-rinsed and dry floors. Apply the product directly to the floors and distribute evenly with a mop or wax spreader. Allow to dry for 30 minutes before walking on the surface. Apply a second coat, taking care to cross it with the first until you obtain the desired level of gloss.

**Dosage:** Base treatment: ready-to-use product, apply as is. Maintenance treatment: dilute 10-20 ml/L in water (1-2 caps every 5 litres).

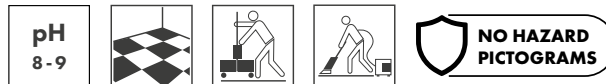

Code	<b>1610</b>	Pcs x Box	2
EAN	8032680391279	Box x Lyr	18
Volume	5 L / 5,2 kg	Box x Plt	72



View the data sheet on your smartphone.

**WX3 WAX & CLEAN** | Floral



Self-polishing floor wax washer

- Removes surface dirt and removes marks and scratches present in the wax film with a single operation
- Non-slip properties
- Self-polishing, easy and quick to use, does not require subsequent polishing operations
- Leaves a pleasant scent in the room

**Directions:** Dilute the product in water according to the instructions, spread it on the surfaces to be treated with a mop or wax spreader. Scrub to remove stubborn build-up. No rinsing required.

**Dosage:** 10-30 ml/L (1-3 caps every 5 litres) depending on the degree of dirt.

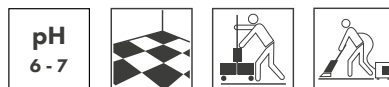

Code	<b>1640</b>	Pcs x Box	2
EAN	8032680391323	Box x Lyr	18
Volume	5 L / 5,1 kg	Box x Plt	72



View the data sheet on your smartphone.

**WX2 WAX REMOVER**



Wax remover for water-based waxes

- Easily removes protective films from waxed floors
- Easy to rinse
- Low foaming product for easier application
- Safe on all types of water-resistant hard floors

**Directions:** Dilute the product in water according to directions, distribute it on the surfaces to be treated with a cloth, mop or scrubber. No rinsing required.

**Dosage:** 50-150 ml/L (5-15 caps every 5 litres) depending on the degree of dirt.



Code	<b>1660</b>	Pcs x Box	2
EAN	8032680391316	Box x Lyr	18
Volume	5 L / 5 kg	Box x Plt	72



View the data sheet on your smartphone.





**SANITEC**  
Professional cleaning solutions



# Multi-surface

# PRODUCTS AND SURFACES: COMMON AREAS

## GLASS, MIRRORS AND DUSTING

Crystal - 1866-S, 2261  
Sanialc - 1830-S



## DISINFECTION

Multi Activ - 1821-S, 1822-S, 1838-S

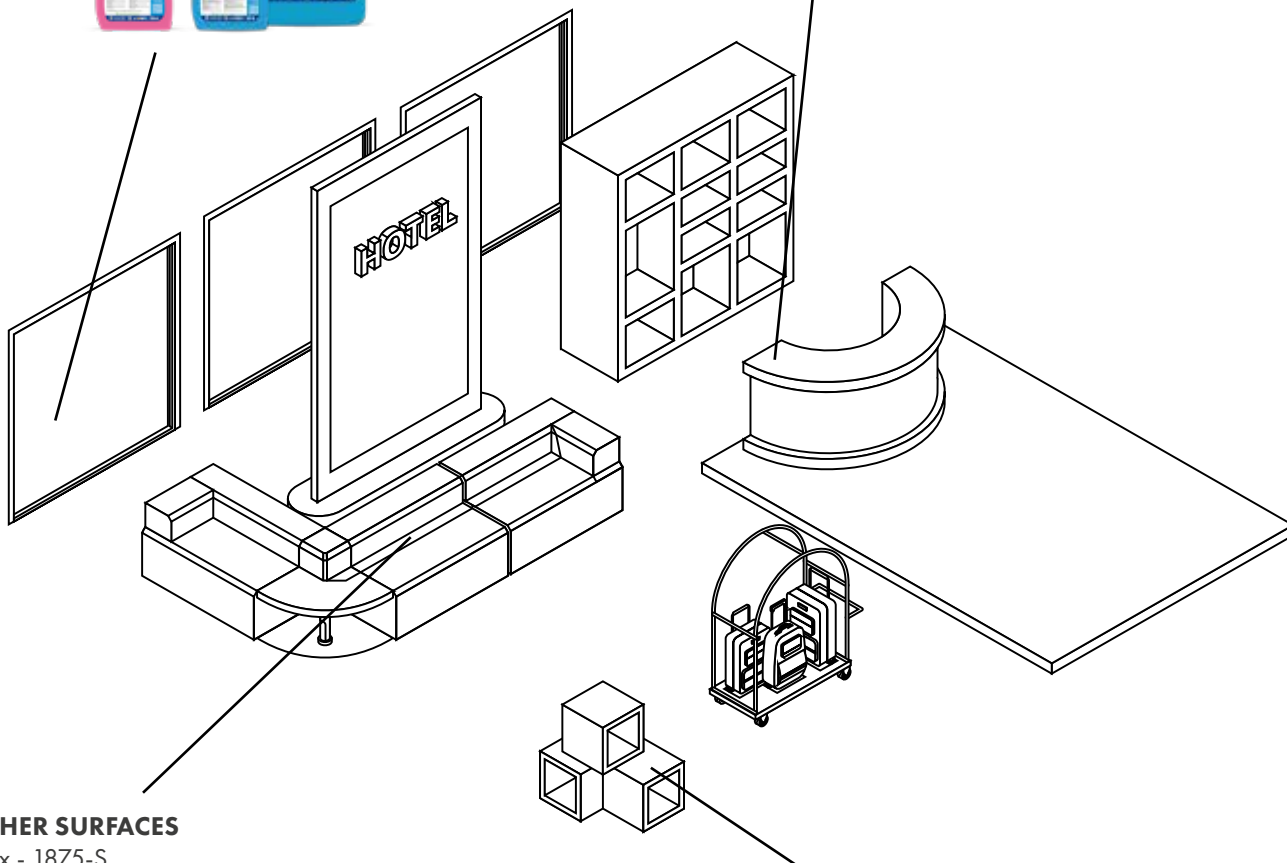

## OTHER SURFACES

Inox - 1875-S,  
Steelpro - 1813  
Silver - 1881  
Wood - 1834  
Leather - 1835  
Deink - 1884-S, 1887

## SURFACE CLEANING

Degreaser Ultra - 1810-S, 1801, 1808-S, 1809



# PRODUCTS AND SURFACES: BATHROOM AND TOILET

## SURFACE AND BATHROOM FITTING CLEANING

Igienikal - 1920-S, 1930-S, 1931  
 Ultrakal - 1910-S  
 Sani Citric - 1913-S



## CHROME SURFACE CLEANING

Steelpro - 1813  
 Inox - 1875-S



## TOILETS AND URINALS

Deo WC Gel - 1943  
 Chlor WC Gel - 1944  
 Blu Power WC Gel - 1946  
 Uri Tabs - 2150



## GLASS, MIRRORS AND DUSTING

Crystal - 1866-S, 2261  
 Sanialc - 1830-S

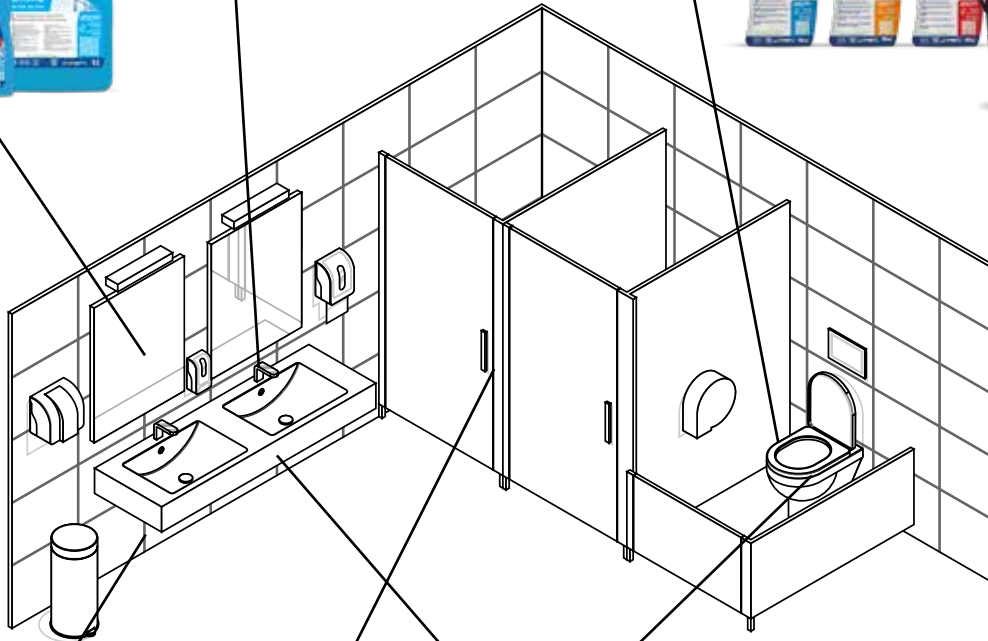

## WHITENING CLEANSING

Active Chlor Foam - 1560-S  
 Active Chlor - 1173  
 Active Chlor Gel - 1562-S  
 Active Oxygen - 1174, 1175-S



## DRAIN MAINTENANCE

Unblocker Gel - 1980  
 Bio Bact - 2410



## DISINFECTION

Multi Activ - 1821-S, 1822-S, 1838-S



## IGIENIKAL GREEN POWER | Floral



**Ecolabel-certified** citric acid-based descaling detergent for bathrooms and bathroom fittings

- EU Ecolabel-certified product with low environmental impact
- Quickly dissolves greasy residues, soap residues and limescale residues from sinks, shower cubicles, taps, bathroom fittings, tiles, etc.
- Leaves surfaces shiny

**Directions:** Dispense the product directly onto the surface to be cleaned, allow it to act for a few minutes and then wipe with a clean, damp cloth. Rinse thoroughly with water.

**Dosage:** Ready to use.



	Code	<b>3103</b>	Pcs x Box	6
	EAN	8032680393686	Box x Lyr	21
	Volume	750 ml	Box x Plt	105



View the data sheet on your smartphone.

## IGIENIKAL | Orchid



Phosphoric and citric acid scented descaling detergent for bathrooms and bathroom fittings

- Quickly dissolves greasy and cosmetic residues and limescale residues from sinks, shower cubicles, taps, bathroom fittings, tiles, etc.
- Prevents limescale build-up
- Leaves surfaces shiny
- Leaves a pleasant fragrance
- Safe on chrome plating

**Directions:** Dispense the product directly onto the surface to be cleaned, allow it to act for a few minutes and then wipe with a clean, damp cloth. Rinse thoroughly with water.

**Dosage:** Ready to use.



	Code	<b>1920-S</b>	Pcs x Box	6
	EAN	8054633830703	Box x Lyr	21
	Volume	750 ml	Box x Plt	105



View the data sheet on your smartphone.

## IGIENIKAL | Balsamic



Phosphoric and citric acid scented descaling detergent for bathrooms and bathroom fittings

- Quickly dissolves greasy and cosmetic residues and limescale residues from sinks, shower cubicles, taps, bathroom fittings, tiles, etc.
- Leaves surfaces shiny
- Leaves a pleasant fragrance
- Safe on chrome plating

**Directions:** Dispense the product directly onto the surface to be cleaned, allow it to act for a few minutes and then wipe with a clean, damp cloth. Rinse thoroughly with water.

**Dosage:** Ready to use.



	Code	<b>1930-S</b>	Pcs x Box	6
	EAN	8032680391521	Box x Lyr	21
	Volume	750 ml	Box x Plt	105



View the data sheet on your smartphone.

	Code	<b>1931</b>	Pcs x Box	2
	EAN	8032680391965	Box x Lyr	18
	Volume	5 L / 5,2 kg	Box x Plt	72



View the data sheet on your smartphone.

ULTRAKAL



Scented descaling detergent made with phosphoric acid and sulphate for bathrooms and bathroom fittings

- Effectively and quickly dissolves limescale and mineral deposits on sinks, shower cubicles, taps, bathroom fittings, tiles, etc.
- Leaves surfaces shiny
- Safe on surfaces to be descaled

**Directions:** Dispense the product directly onto the surface to be cleaned, allow it to act for a few minutes and then wipe with a clean, damp cloth. Rinse thoroughly with water.

**Dosage:** Ready to use.

pH  
0,7 - 1,7



Code	1910-S	Pcs x Box	6
EAN	8032680393204	Box x Lyr	21
Volume	750 ml	Box x Plt	105



View the data sheet on your smartphone.

SANI CITRIC | Floral



Citric acid-based descaling gel cleaner for daily cleaning of bathrooms and bathroom fittings

- Ideal for daily cleaning, effective in removing limescale
- Gel formula for better adhesion even on vertical surfaces
- Easy to rinse
- Safe product, does not require PPE during use

**Directions:** Dispense the product directly onto the surface to be cleaned, allow it to act for a few minutes and then wipe with a clean, damp cloth. Rinse thoroughly with water.

**Dosage:** Ready to use.

pH  
2 - 3



Code	1913-S	Pcs x Box	6
EAN	8054633836408	Box x Lyr	21
Volume	1000 ml	Box x Plt	105



View the data sheet on your smartphone.

## MULTI ACTIV | Pine



Ready-to-use disinfectant for surfaces according to **Italian Ministry of Health**, Registration no. 20058.

- Eliminates 99.9% of bacteria, fungi and viruses
- Cleans and eliminates bad odours
- Effectively removes gram-positive and gram-negative bacteria, fungi, moulds, and both enveloped and non-enveloped viruses from smooth surfaces, thanks to its formulation with active ingredients
- Suitable for disinfecting kitchens, bathrooms and all surfaces in contact with food

**Directions:** For normal cleaning, apply directly to the surface to be treated and then dry with a cloth or paper. For disinfection, leave on for at least 5 minutes to obtain bactericidal action or for at least 15 minutes to also obtain fungicidal and virucidal action. For virucidal action, apply the product to the previously cleaned surface. When disinfecting surfaces that may come into direct contact with food, rinse with potable water.

**Dosage:** See the terms of use in the table.



Code	1822-S	Pcs x Box	6
EAN	8032680392009	Box x Lyr	21
Volume	750 ml	Box x Plt	105



View the data sheet on your smartphone.

### Active ingredient

Alkyl dimethylbenzyl ammonium chloride 0.4 g/100 g

## MULTI ACTIV | Lemon



Ready-to-use disinfectant for surfaces according to **Italian Ministry of Health**, Registration no. 20058.

- Eliminates 99.9% of bacteria, fungi and viruses
- Cleans and eliminates bad odours
- Effectively removes gram-positive and gram-negative bacteria, fungi, moulds, and both enveloped and non-enveloped viruses from smooth surfaces, thanks to its formulation with active ingredients
- Suitable for disinfecting kitchens, bathrooms and all surfaces in contact with food

**Directions:** For normal cleaning, apply directly to the surface to be treated and then dry with a cloth or paper. For disinfection, leave on for at least 5 minutes to obtain bactericidal action or for at least 15 minutes to also obtain fungicidal and virucidal action. For virucidal action, apply the product to the previously cleaned surface. When disinfecting surfaces that may come into direct contact with food, rinse with potable water.

**Dosage:** See the terms of use in the table.



Code	1838-S	Pcs x Box	6
EAN	8054633838013	Box x Lyr	21
Volume	750 ml	Box x Plt	105



View the data sheet on your smartphone.

### Active ingredient

Alkyl dimethylbenzyl ammonium chloride 0.4 g/100 g



**Product code** 1821-S, 1838-S, 1822-S

**Active ingredient** Alkyl dimethylbenzyl ammonium chloride 0.4 g/100 g

### Bactericidal efficacy

### Fungicidal efficacy

### Virucidal efficacy

### Regulation

UNI EN 1276:2009  
UNI EN 13697:2015

UNI EN 1650:2008  
UNI EN 13697:2001

UNI EN 14476:2019  
UNI EN 16777:2019

### Tested organisms

*Pseudomonas aeruginosa*  
*Staphylococcus aureus*  
*Enterococcus hirae*  
*Escherichia coli*

*Candida albicans*  
*Penicillium verrucosum*

*Vaccinia virus*  
*Adenovirus type 5*,  
*Murine norovirus MNV*

### Conditions of use

Concentration: Ready to use  
Contact time: 5 minutes  
Dirt conditions

Concentration: Ready to use  
Contact time: 15 minutes  
Dirt conditions

Concentration: Ready to use  
Contact time: 15 minutes  
Clean conditions

## ACTIVE CHLOR FOAM

Product pending registration as **Biocide**



Sodium hypochlorite-based degreasing and whitening detergent for hard surfaces

- Cleans, deodorizes and removes stains in a single solution
- It degreases thoroughly and is also effective on pigmented dirt
- It forms a compact foam that also adheres to vertical walls
- Easy to rinse
- Whitening effect on grouting

**Directions:** Dispense the product directly onto the surface to be cleaned, allow it to act for a few minutes and then wipe with a clean, damp cloth. Rinse thoroughly with water.

**Dosage:** Ready to use.



Code	1560-S	Pcs x Box	6
EAN	8032680393167	Box x Lyr	21
Volume	750 ml	Box x Plt	105



View the data sheet on your smartphone.

## ACTIVE CHLOR

Product pending registration as **Biocide**



Concentrated liquid detergent based on non-foaming sodium hypochlorite for hard surfaces

- Cleans, deodorizes and removes stains in a single solution
- Effectively removes stubborn dirt
- Eliminates unpleasant odours
- Easy rinsing thanks to its non-foaming formula

**Directions:** Ideal for places open to the public such as hospitals, schools, hotels, changing rooms, toilets and in the agri-food sector. Ideal for both manual washing with mop and rag, and for washing with scrubbers, with a lance or in recirculation systems.

Dilute the product in water according to directions, distribute it on the surfaces to be treated with a cloth, mop or scrubber. No rinsing required.

**Dosage:** 20-40 ml/L (2-4 caps every 5 litres) depending on the degree of soiling.

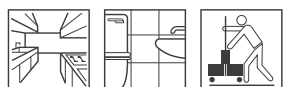

Code	1173	Pcs x Box	2
EAN	8054633831250	Box x Lyr	18
Volume	5 L / 5,8 kg	Box x Plt	72



View the data sheet on your smartphone.

## ACTIVE CHLOR GEL

Product pending registration as **Biocide**



Degreasing and whitening detergent with sodium hypochlorite for hard surfaces

- Cleans, deodorizes and removes stains in a single solution
- Whitening effect on grouting
- Degreases thoroughly and is also effective on pigmented dirt
- Easy to rinse
- It adheres to walls thanks to its gel formula

**Directions:** Dispense the product directly onto the surface to be cleaned, allow it to act for a few minutes and then wipe with a clean, damp cloth. Rinse thoroughly with water.

**Dosage:** Ready to use.



Code	1562-S	Pcs x Box	6
EAN	8032680399121	Box x Lyr	21
Volume	1000 ml	Box x Plt	105



View the data sheet on your smartphone.

# BATHROOM AND TOILET

## ACTIVE CHLOR TABLET

Active chlorine tablet sanitiser for cleaning washable surfaces and treating fruit and vegetable washing water



- Cleans, deodorizes and removes stains in a single solution
- Can be used to treat fruit and vegetable washing solutions
- Practical tablet format, easy to dose and avoids waste
- Each tablet releases 1500 ppm of active chlorine in one litre

**Directions:** As a surface cleaner: Dilute the product according to the recommended doses and apply it with a sponge, cloth or mop, then rinse with plenty of water. Treatment of aqueous solution for washing fruit and vegetables: Dilute the product according to the recommended doses, immerse fruit, vegetables and greens in the washing solution for 2-3 minutes, then rinse thoroughly with water.

**Dosage:** Surface cleaner: 2 tablets every 5 litres. Treatment of aqueous solution for washing fruit and vegetables: 1 tablet every 3 litres.

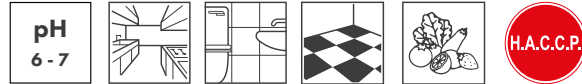

150 TABS	Code	2122	Pcs x Box	12
	EAN	8054633838006	Box x Lyr	12
	Volume	150 Tabs	Box x Plt	72



## ACTIVE OXYGEN

Product pending registration as **Biocide**

Liquid detergent based on active oxygen for washing hard surfaces



- Easily removes dirt residues
- Cleans, deodorizes and removes stains in a single solution
- Eliminates unpleasant odours

**Directions:** Dilute the product in water according to directions, distribute it on the surfaces to be treated with a cloth, mop or scrubber. No rinsing required. Ideal for both mop and rag washing as well as spray cleaning.

**Dosage:** 20-40 ml/L (2-4 caps every 5 litres) depending on the degree of soiling.

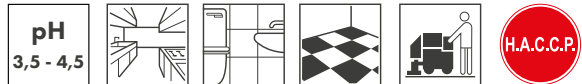

5L	Code	1174	Pcs x Box	2
	EAN	8054633831267	Box x Lyr	18
	Volume	5 L / 5,2 kg	Box x Plt	72



## WC GEL GREEN POWER | Pine

Descaling detergent with **Ecolabel certificate** made with citric acid and lactic acid for toilets and urinals



- EU Ecolabel-certified product with low environmental impact
- Effective in removing limescale and organic dirt
- It adheres perfectly to vertical surfaces thanks to the gel formula
- Quick and easy to apply thanks to the bottle with multi-jet action cap for a wide coverage of the surface to be cleaned

**Directions:** Run water into the toilet bowl/urinal. Apply the product around the bowl and on the water flow walls. Leave on for 15 minutes, scrub with a brush or abrasive cloth to remove more stubborn stains, then run water to rinse.

**Dosage:** Ready to use.



700 ml	Code	1945	Pcs x Box	8
	EAN	8050999570703	Box x Lyr	20
	Volume	700 ml	Box x Plt	100



**BLU POWER WC GEL** | Balsamic



Acid descaling cleaner based on citric, lactic, and sulfamic acids for toilets and urinals for toilets and urinals

- Effectively removes limescale, stubborn encrustations and organic dirt
- Eliminates odours and leaves a pleasant scent
- It adheres perfectly to vertical surfaces thanks to the gel formula
- Quick and easy to apply thanks to the bottle with multi-jet action cap for a wide coverage of the surface to be cleaned

**Directions:** Run water into the toilet bowl/urinal. Apply the product around the bowl and on the water flow walls. Leave on for 15 minutes, scrub with a brush or abrasive cloth to remove more stubborn stains, then run water to rinse.

**Dosage:** Ready to use.

	Code	1946	Pcs x Box	8
	EAN	8050999571519	Box x Lyr	20
	Volume	700 ml	Box x Plt	100

View the data sheet on your smartphone.

**DEO WC GEL** | Pine



Acidic toilet and urinal descaler with long-lasting fragrance

- Removes limescale, stubborn encrustations and organic dirt
- Eliminates odours and leaves a pleasant scent
- It adheres perfectly to vertical surfaces thanks to the gel formula
- Quick and easy to apply thanks to the bottle with multi-jet action cap for a wide coverage of the surface to be cleaned

**Directions:** Run water into the toilet bowl/urinal. Apply the product around the bowl and on the water flow walls. Leave on for 15 minutes, scrub with a brush or abrasive cloth to remove more stubborn stains, then run water to rinse.

**Dosage:** Ready to use.

	Code	1943	Pcs x Box	8
	EAN	8050999570673	Box x Lyr	20
	Volume	700 ml	Box x Plt	100

View the data sheet on your smartphone.

**CHLOR WC GEL** | Eucalyptus



Sodium hypochlorite cleaner with whitening effect for toilets and urinals

- Effectively removes dirt
- Eliminates odours
- It adheres perfectly to vertical surfaces thanks to the gel formula
- Quick and easy to apply thanks to the bottle with multi-jet action cap for a wide coverage of the surface to be cleaned

**Directions:** Run water into the toilet bowl/urinal. Apply the product around the bowl and on the water flow walls. Leave on for 15 minutes, scrub with a brush or abrasive cloth to remove more stubborn stains, then run water to rinse.

**Dosage:** Ready to use.

	Code	1944	Pcs x Box	8
	EAN	8050999570697	Box x Lyr	20
	Volume	700 ml	Box x Plt	100

View the data sheet on your smartphone.

# BATHROOM AND TOILET

## UNBLOCKER GEL



Highly effective alkaline descaling gel with sodium hypochlorite

- It acts quickly on the clog, even overcoming stagnant water thanks to the high specific weight of its special gel formula
- Dissolves all the deposits that normally create blockage
- Prevents the formation of bad odours
- Ideal for preventative maintenance of drains and runoffs

**Directions:** Pour the product directly into the affected drain. Wait 5 minutes. Run hot water.

**Dosage:** Ready to use. Ordinary maintenance: 200 ml per week. Stubborn clog: 500 ml

pH  
13 - 14



Code	1980	Pcs x Box	6
EAN	8050999572189	Box x Lyr	21
Volume	900 ml	Box x Plt	105



View the data sheet on your smartphone.

## BIO BACT



Biological odour-eliminating enzymatic product for the maintenance of pipes, drains and manholes

- Eliminates bad odours
- Avoids blockages and ensures efficient drainage at all times
- Regular use of the product reduces the costs of Maintenance and disposal of septic tanks, cesspits, traps, and grease traps
- Gentle on the materials it comes into contact with
- Effective for the deodorizing treatment of waste and its storage and collection containers

**Directions and dosage:** Initial or strong treatment: 400-600 ml of product. Maintenance treatment: 120-180 ml of product once a week. Anti-odour treatment: apply directly to waste and surfaces diluted by 10-20 ml/litre in water. For greater product effectiveness, perform the treatments after completing the cleaning operations.

pH  
6 - 7



Code	2410	Pcs x Box	2
EAN	8032680392535	Box x Lyr	18
Volume	5 L / 5 kg	Box x Plt	72



View the data sheet on your smartphone.

## URI TABS



Odour-disrupting detergent with biological activators in tablets for urinals

- Slow-dissolving tablets to remove and prevent the formation of urinary scale
- Eliminates bad odours and leaves the room pleasantly scented
- Easy to use, guarantees long lasting action

**Directions:** Place the tablet directly inside the urinal.

**Dosage:** 1 tablet per urinal.

pH  
7,5 - 8,5



Code	2150	Pcs x Box	1
EAN	8032680392344	Box x Lyr	15
Volume	3 kg	Box x Plt	105



View the data sheet on your smartphone.

**BIO URISCREEN**

Disintegrating anti-odour net with biological activators for urinals



- Triple function: cleans, descales and deodorizes
- Inhibits the formation of urine scale
- Long lasting efficacy

**Directions:** Place the tablet directly inside the urinal.  
**Dosage:** 1 screen per urinal.



Code	<b>2430</b>	Pcs x Box	12
EAN	8032680391088	Box x Lyr	20
Volume	0,2	Box x Plt	100



View the data sheet on your smartphone.

**URI DEO**

Flexible urinal deodorant screen



- Eliminates odours
- Releases the fragrance constantly over time
- Keeps bathrooms dry and clean thanks to the splash-guard construction that avoids the spray of urine

**Directions:** Remove the urinal screen from the packaging and place it in the urinal. The air freshening process begins immediately. Replace with a new screen when the one in use no longer smells fresh.

**Dosage:** One screen per urinal.



Orange screen code **2431** - Mango  
 Red screen code **2432** - Mint

Code	<b>2431</b>	Pcs x Box	50
EAN	8032680393952	Box x Lyr	13
Volume	0,2	Box x Plt	104



View the data sheet on your smartphone.

Code	<b>2432</b>	Pcs x Box	50
EAN	8054633830505	Box x Lyr	13
Volume	0,2	Box x Plt	104



View the data sheet on your smartphone.

## CRYSTAL GREEN POWER



**Ecolabel-certified** multi-purpose cleaner for glass, mirrors and dusting

- EU Ecolabel-certified product with low environmental impact
- Leaves surfaces clean and shiny without streaks
- Ideal for glass, mirrors and chrome plated surfaces

**Directions:** Dispense the product directly onto the surface to be cleaned and rub until completely dry.

**Dosage:** Ready to use.

pH  
10 - 11



Code	3102	Pcs x Box	6
EAN	8032680393655	Box x Lyr	21
Volume	750 ml	Box x Plt	105



View the data sheet on your smartphone.

## CRYSTAL | Floral



Multipurpose cleaner for glass, mirrors and dusting

- Leaves surfaces clean and shiny without streaks
- Ideal for glass, mirrors and chrome plated surfaces
- Leaves the room pleasantly scented

**Directions:** Dispense the product directly onto the surface to be cleaned and rub until completely dry.

**Dosage:** Ready to use.

pH  
10,5 - 11,5



Code	1866-S	Pcs x Box	6
EAN	8032680391422	Box x Lyr	21
Volume	750 ml	Box x Plt	105



View the data sheet on your smartphone.



Code	2261	Pcs x Box	2
EAN	8032680391408	Box x Lyr	18
Volume	5 L / 5 kg	Box x Plt	72



View the data sheet on your smartphone.

## ULTRA DEGREASER GREEN POWER



**Ecolabel-certified** universal degreaser for stubborn dirt

- EU Ecolabel-certified product with low environmental impact
- Effectively removes dirt, grease, oil and charred residues
- Ideal for the catering sector, industry, garages, offices, warehouses, hospitals

**Directions:** Dispense the product directly onto the surface to be cleaned, allow it to act for a few minutes and then wipe with a clean, damp cloth. Rinse thoroughly with water.

**Dosage:** Ready to use.

pH  
10 - 11



Code	3101	Pcs x Box	6
EAN	8032680393693	Box x Lyr	21
Volume	750 ml	Box x Plt	105



View the data sheet on your smartphone.

## DEGREASER ULTRA | Lemon



Universal degreaser for stubborn dirt

- Degreasing and sanitizing action
- Effectively removes organic dirt, grease, oil and charred residues
- Leaves a pleasant scent in the room

**Directions:** Dispense the product directly onto the surface to be cleaned, allow it to act for a few minutes and then wipe with a clean, damp cloth. Rinse thoroughly with water.

**Dosage:** Ready to use.



	Code	1810-5	Pcs x Box	6
	EAN	8032680392689	Box x Lyr	21
	Volume	750 ml	Box x Plt	105



	Code	1801	Pcs x Box	2
	EAN	8032680391385	Box x Lyr	18
	Volume	5 L / 5,1 kg	Box x Plt	72



## DEGREASER ULTRA | Marseille



Universal degreaser for stubborn dirt

- Degreasing and sanitizing action
- Effectively removes organic dirt, grease, oil and charred residues
- Leaves a pleasant scent in the room

**Directions:** Dispense the product directly onto the surface to be cleaned, allow it to act for a few minutes and then wipe with a clean, damp cloth. Rinse thoroughly with water.

**Dosage:** Ready to use.



	Code	1808-5	Pcs x Box	6
	EAN	8032680391330	Box x Lyr	21
	Volume	750 ml	Box x Plt	105



	Code	1809	Pcs x Box	2
	EAN	8032680391354	Box x Lyr	18
	Volume	5 L / 5,1 kg	Box x Plt	72



## SANIALC | Floral





Quick-drying universal cleaner with quaternary ammonium salts and alcohol for hard surfaces

- Cleans and degreases without needing to rinse
- Dries quickly without leaving streaks on surfaces
- Leaves the room pleasantly scented

**Directions:** Dispense the product directly onto the surface to be cleaned, allow it to act for a few minutes and then wipe with a clean, damp cloth.

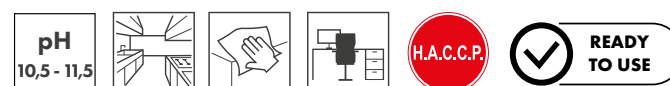
**Dosage:** Ready to use.



	Code	1830-5	Pcs x Box	6
	EAN	8032680391392	Box x Lyr	21
	Volume	750 ml	Box x Plt	105



# DISINFECTANTS

## MULTI ACTIV | Unscented



Ready-to-use disinfectant for surfaces according to **Italian Ministry of Health**, Registration no. 20058.

- Eliminates 99.9% of bacteria, fungi and viruses
- Cleans and eliminates bad odours
- Effectively removes gram-positive and gram-negative bacteria, fungi, moulds, and both enveloped and non-enveloped viruses from smooth surfaces, thanks to its formulation with active ingredients
- Suitable for disinfecting kitchens, bathrooms and all surfaces in contact with food

**Directions:** For normal cleaning, apply directly to the surface to be treated and then dry with a cloth or paper. For disinfection, leave on for at least 5 minutes to obtain bactericidal action or for at least 15 minutes to also obtain fungicidal and virucidal action. For virucidal action, apply the product to the previously cleaned surface. When disinfecting surfaces that may come into direct contact with food, rinse with potable water.

**Dosage:** See the terms of use in the table.



Code	1821-S	Pcs x Box	6
EAN	8032680391446	Box x Lyr	21
Volume	750 ml	Box x Pkt	105



View the data sheet on your smartphone.

### Active ingredient

Alkyl dimethylbenzyl ammonium chloride 0.4 g/100 g

## MULTI ACTIV | Lemon



Ready-to-use disinfectant for surfaces according to **Italian Ministry of Health**, Registration no. 20058.

- Eliminates 99.9% of bacteria, fungi and viruses
- Cleans and eliminates bad odours
- Effectively removes gram-positive and gram-negative bacteria, fungi, moulds, and both enveloped and non-enveloped viruses from smooth surfaces, thanks to its formulation with active ingredients
- Suitable for disinfecting kitchens, bathrooms and all surfaces in contact with food

**Directions:** For normal cleaning, apply directly to the surface to be treated and then dry with a cloth or paper. For disinfection, leave on for at least 5 minutes to obtain bactericidal action or for at least 15 minutes to also obtain fungicidal and virucidal action. For virucidal action, apply the product to the previously cleaned surface. When disinfecting surfaces that may come into direct contact with food, rinse with potable water.

**Dosage:** See the terms of use in the table.



Code	1838-S	Pcs x Box	6
EAN	8054633838013	Box x Lyr	21
Volume	750 ml	Box x Pkt	105



View the data sheet on your smartphone.

### Active ingredient

Alkyl dimethylbenzyl ammonium chloride 0.4 g/100 g

**MULTI ACTIV** | Pine



Ready-to-use disinfectant for surfaces according to **Italian Ministry of Health**, Registration no. 20058.

- Eliminates 99.9% of bacteria, fungi and viruses
- Cleans and eliminates bad odours
- Effectively removes gram-positive and gram-negative bacteria, fungi, moulds, and both enveloped and non-enveloped viruses from smooth surfaces, thanks to its formulation with active ingredients
- Suitable for disinfecting kitchens, bathrooms and all surfaces in contact with food

**Directions:** For normal cleaning, apply directly to the surface to be treated and then dry with a cloth or paper. For disinfection, leave on for at least 5 minutes to obtain bactericidal action or for at least 15 minutes to also obtain fungicidal and virucidal action. For virucidal action, apply the product to the previously cleaned surface. When disinfecting surfaces that may come into direct contact with food, rinse with potable water.

**Dosage:** See the terms of use in the table.



Code	<b>1822-S</b>	Pcs x Box	6
EAN	8032680392009	Box x Lyr	21
Volume	750 ml	Box x Plt	105



View the data sheet on your smartphone.

**Active ingredient**

Alkyl dimethylbenzyl ammonium chloride 0.4 g/100 g



**Product code** 1821-S, 1838-S, 1822-S

**Active ingredient** Alkyl dimethylbenzyl ammonium chloride 0.4 g/100 g

**Bactericidal efficacy**

**Fungicidal efficacy**

**Virucidal efficacy**

**Regulation**

UNI EN 1276:2009  
UNI EN 13697:2015

UNI EN 1650:2008  
UNI EN 13697:2001

UNI EN 14476:2019  
UNI EN 16777:2019

**Tested organisms**

Pseudomonas aeruginosa  
Staphylococcus aureus  
Enterococcus hirae  
Escherichia coli

Candida albicans  
Penicillium verrucosum

Vaccinia virus  
Adenovirus type 5,  
Murine norovirus MNV

**Conditions of use**

Concentration: Ready to use  
Contact time: 5 minutes  
Dirt conditions

Concentration: Ready to use  
Contact time: 15 minutes  
Dirt conditions

Concentration: Ready to use  
Contact time: 15 minutes  
Clean conditions

# OTHER SURFACES

## INOX



Specific degreasing detergent for steel surfaces

- Effectively removes greasy dirt, food residues and stubborn grime
- Makes surfaces shiny
- Leaves a protective layer on the treated surface
- Suitable for all metal surfaces such as stainless steel, copper, aluminium and brass

**Directions:** Dispense the product directly onto the surface to be cleaned, allow it to act for a few minutes and then wipe with a clean, damp cloth. Rinse thoroughly with water.

**Dosage:** Ready to use.

pH  
2,2 - 3,2



Code	1875-S	Pcs x Box	6
EAN	8032680392115	Box x Lyr	21
Volume	750 ml	Box x Plt	105



View the data sheet on your smartphone.

## STEEL PRO



Ready-to-use maintenance polish for steel surfaces

- Effectively removes dirt, grease, fingerprints and other types of dirt that adhere to surfaces
- Polishes and protects all steel surfaces
- Forms a protective layer that delays the formation of stains and limescale

**Directions:** Dispense the product directly onto the surface to be cleaned and rub until completely dry.

**Dosage:** Ready to use.

pH  
6 - 7



Code	1813	Pcs x Box	6
EAN	8054633830598	Box x Lyr	21
Volume	500 ml	Box x Plt	105



View the data sheet on your smartphone.

## SILVER



Degreasing and deoxidizing detergent for cleaning silver, aluminium, copper and brass surfaces

- Quickly removes black oxidation stains from silver, through immersion only, no scrubbing required
- Leaves surfaces shiny

**Directions:** Dispense the product directly onto the surface to be cleaned, allow it to act for a few minutes and then wipe with a clean, damp cloth. Soaking: Pour the undiluted product into a bowl of water, then completely immerse the objects for a few minutes. When necessary, use a cloth or brush directly on the oxidation/dirt stains, then rinse and dry.

**Dosage:** 20-50 ml/L

pH  
0,5 - 1,5



Code	1881	Pcs x Box	2
EAN	8032680391484	Box x Lyr	18
Volume	5 L / 5,2 kg	Box x Plt	72



View the data sheet on your smartphone.

WOOD | Floral



Mild detergent with neutral pH for all wood surfaces

- Removes dirt and tough stains without leaving any residue
- Nourishes the wood
- Formulated with natural waxes
- Safe on treated surfaces

**Directions:** Dispense the product directly onto the surface to be cleaned and rub until completely dry.

**Dosage:** Ready to use.

pH  
6,5 - 7,5



Code	1834	Pcs x Box	6
EAN	8054633837047	Box x Lyr	26
Volume	500 ml	Box x Plt	130



View the data sheet on your smartphone.

LEATHER | Floral



Mild neutral pH cleanser ideal for cleaning and revitalising all leather and eco-leather surfaces

- Removes dirt and tough stains without leaving any residue
- Formulated with a rich blend of natural waxes, it cleanses, nourishes and revives, giving softness and helping to maintain the original appearance of the skin
- Nourishes the skin naturally
- Safe on treated surfaces

**Directions:** Dispense the product directly onto the surface to be cleaned and rub until completely dry.

**Dosage:** Ready to use.

pH  
6,5 - 7,5



Code	1835	Pcs x Box	6
EAN	8054633837054	Box x Lyr	26
Volume	500 ml	Box x Plt	130



View the data sheet on your smartphone.

DEINK



Solvent-based degreaser for ink, glue and particulates

- Quickly removes ink, marker, stamp stains, etc.
- Also effective on particulate matter deposits such as smog and soot
- Quickly dissolves glue residue, grease and industrial greasy dirt

**Directions:** Dispense the product directly onto the surface to be cleaned, allow it to act for a few minutes and then wipe with a clean, damp cloth.

**Dosage:** Ready to use.

pH  
10,5 - 11,5



Code	1884-5	Pcs x Box	6
EAN	8032680391477	Box x Lyr	21
Volume	750 ml	Box x Plt	105



View the data sheet on your smartphone.



Code	1887	Pcs x Box	2
EAN	8032680392221	Box x Lyr	18
Volume	5 L / 5 kg	Box x Plt	72



View the data sheet on your smartphone.



# Dosy Cabinet

Dosy Cabinet is a practical wall-mounted dispensing system for concentrated detergents that makes it easy and safe to obtain a product diluted to the correct concentration for use.

The system is versatile and allows the concentrated product to be dosed directly into the bottle or bucket, avoiding overdosing of products and facilitating use in different applications.



**One pack of Dosy concentrates is equivalent to 300 bottles of diluted product**

$$6 \text{ pcs x } \text{1000 ML} = 300 \text{ pcs x } \text{500 ML}$$

## Advantages of the Dosy system:

- Optimisation of detergent storage space
- Reduction of transport and disposal costs
- Maximum safety of use during the dilution phase

HC4 SURFACE | Floral fresh



Ultra-concentrated floor cleaner

- Effectively degreases and removes dirt from all washable surfaces, even delicate ones such as marble
- Does not require rinsing and leaves no streaks
- Leaves a pleasant fragrance
- The product at the concentration of use has no CLP hazard statement
- One litre of concentrate yields 50 5L buckets of ready-to-use product

**Directions:** Dilute the product in water according to directions, distribute it on the surfaces to be treated with a cloth, mop or scrubber. No rinsing required.

**Dosage:** 20 ml (one dose with dispenser or measuring cap) in 5 litres of water.

pH  
9.5 - 10.5



Code	1706	Pcs x Box	6
EAN	8054633835296	Box x Lyr	15
Volume	1000 ml	Box x Plt	90



View the data sheet on your smartphone.

HC10 BAKTERIO | Fragrance-free



Disinfectant according to Italian Ministry of Health, Registration no. 15446, for environmental use with bactericidal, fungicidal and virus (virus with envelope) activity.

- Eliminates 99.9% of bacteria, fungi and viruses
- Eliminates bad odours
- Does not corrode metals, does not stain surfaces
- The product at the concentration of use has no CLP hazard statement
- One litre of concentrate yields 50 5L buckets of ready-to-use product

**Directions:** BAKTERIO® should be used diluted to disinfect, cleanse and deodorise by applying the solution with a mop, cloth or sponge.

**Dosage:** For routine cleaning dilute the product in 1 to 3% water and leave for 5 minutes. To disinfect and vigorously deodorise, dilute in water at a ratio of 20% and leave on for at least 5 minutes for bactericidal activity or at least 15 minutes for fungicidal and virucidal activity (viruses with envelope). For virucidal action, apply the product to the previously cleaned surface.

pH  
10 - 11



Code	1713	Pcs x Box	6
EAN	8054633836262	Box x Lyr	15
Volume	1000 ml	Box x Plt	90



View the data sheet on your smartphone.

**Active ingredient**

Alkyl dimethylbenzyl ammonium chloride 3 g/100 g



**Product code** 1540N-S, 1541, 1544, 1713

**Active ingredient** Alkyl dimethylbenzyl ammonium chloride 3 g/100 g

**Bactericidal efficacy**

**Fungicidal efficacy**

**Virucidal efficacy**

**Regulation** UNI EN 1276:2009  
UNI EN 13697:2001

UNI EN 1650:2008  
UNI EN 13697:2001

UNI EN 14476:2019  
UNI EN 16777:2019

**Tested organisms**

Pseudomonas aeruginosa  
Staphylococcus aureus  
Enterococcus hirae  
Escherichia coli

Candida albicans  
Penicillium verrucosum

Vaccinia virus  
Adenovirus type 5,  
Murine norovirus MNV

**Conditions of use**

Concentration: 5%  
Contact time: 5 minutes  
Dirt conditions

Concentration: 5%  
Contact time: 15 minutes  
Dirt conditions

Concentration: 20%  
Contact time: 15 minutes  
Clean conditions

# CONCENTRATED DOSY SYSTEM

## HC9 DEGRI | Floral fresh



Ultra-concentrated degreasing detergent for hard surfaces

- Effective in the removal of greasy and organic dirt
- Leaves a pleasant fragrance
- The product at the concentration of use has no CLP hazard statement
- One litre of concentrate yields 50 500ml bottles of ready-to-use product

**Directions:** Dilute the product in the appropriate bottle. Dispense the product directly onto the surface to be cleaned, allow it to act for a few minutes and then wipe with a clean, damp cloth. Rinse thoroughly with water. Suitable for cleaning slicers, meat mincers, equipment in general, surfaces, steel tables, etc. Can also be used on aluminium surfaces

**Dosage:** 20 ml (one dose with dispenser or measuring cap) in 500 ml of water.



Code	1709	Pcs x Box	6
EAN	8054633836255	Box x Lyr	15
Volume	1000 ml	Box x Plt	90



View the data sheet on your smartphone.

## HC2A IGIENIKAL | Floral fresh



Ultra-concentrated scented descaling detergent

- Quickly dissolves dirt, limescale and soap residue from sinks, shower cubicles, faucets, bathroom fittings, tiles
- Leaves a pleasant fragrance
- The product at the concentration of use has no CLP hazard statement
- One litre of concentrate yields 50 500ml bottles of ready-to-use product

**Directions:** Dilute the product in the appropriate bottle. Dispense the product directly onto the surface to be cleaned, allow it to act for a few minutes and then wipe with a clean, damp cloth. Rinse thoroughly with water. Suitable for cleaning slicers, meat mincers, general equipment, surfaces, steel tables, etc. Can also be used on aluminium surfaces.

**Dosage:** 20 ml (one dose with dispenser or measuring cap) in 500 ml of water.



Code	1703	Pcs x Box	6
EAN	8054633835265	Box x Lyr	15
Volume	1000 ml	Box x Plt	90



View the data sheet on your smartphone.

## HC3 CRYSTAL | Floral fresh



Ultra-concentrated glass and multipurpose cleaner

- Cleanses thoroughly and without leaving streaks
- Leaves a pleasant fragrance
- The product at the concentration of use has no CLP hazard statement
- One litre of concentrate yields 50 500ml bottles of ready-to-use product

**Directions:** Dilute the product in the appropriate bottle. Dispense the product directly onto the surface to be cleaned, leave for a few minutes and then wipe with a clean cloth until completely dry.

**Dosage:** 20 ml (one dose with dispenser or measuring cap) in 500 ml of water.



Code	1705	Pcs x Box	6
EAN	8054633835289	Box x Lyr	15
Volume	1000 ml	Box x Plt	90



View the data sheet on your smartphone.

## DOSY CABINET



High-efficiency wall-mounted dispenser for concentrated products

- Allows the dispensing and dilution of highly effective concentrates in ready-to-use solutions
- No need for electrical, plumbing
- Equipped with a practical safety lock

Dosy for bottle	Code	213
	EAN	8054633837108
	Volume	-

Dosy for bucket	Code	214
	EAN	8054633837115
	Volume	-

## RIGHT DOSE CAP

Dispensing cap that allows the correct amount of product to be dispensed manually



- Allows the dispensing and dilution of highly effective concentrates in ready-to-use solutions

Cap	Code	1716-S
	EAN IC	18050444497743
	Volume	-

## Dosy accessory kit

Dosy accessory kits consist of:

- Transparent 500 ml bottle x 6 pcs;
- Cap/Sprayer x 6 pcs;
- Label to apply to bottle x 6 pcs;
- Label to apply to Cabinet x 1 pc;
- Label to apply to wall x 1 pc.

### SN KIT HC2A

LIMESCALE REMOVER

Code **1703KIT**

### SN KIT HC9

SURFACE DEGREASER

Code **1709KIT**

### SN KIT HC3

GLASS MIRRORS AND DUSTING

Code **1705KIT**

### SN KIT HC10

SURFACE DISINFECTANT

Code **1713KIT**

### SN KIT HC4

FLOOR CLEANER

Code **1706KIT**

## DETERGENT KIT

A complete line of cleaning products to satisfy every professional need



Code **1007-S**  
EAN IC 18050999572445



### CREAM SOAP

Iris Blue

Code **1020**  
EAN 8032680397523  
Pack 1 pcs x 1000 ml

Product details on page 124



### DEGREASER ULTRA

Lemon

Code **1810-S**  
EAN 8032680392689  
Pack 1 pcs x 750 ml

Product details on page 75



### CRYSTAL

Floral

Code **1866-S**  
EAN 8032680391422  
Pack 1 pcs x 750 ml

Product details on page 74



### SANIALC

Code **1426N-S**  
EAN 8032680392276  
Pack 1 pcs x 1000 ml

Product details on page 57



### IGIENIKAL

Balsamic

Code **1930-S**  
EAN 8032680391521  
Pack 1 pcs x 750 ml

Product details on page 66



### BLU POWER WC GEL

Balsamic

Code **1946**  
EAN 8050999571519  
Pack 1 pcs x 700 ml

Product details on page 71



## GREEN POWER KIT

A complete selection of **Ecolabel-certified** cleaning products, to satisfy every professional need

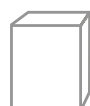

Code **1005-S**  
EAN IC 18050444498429



### MOUSSE SOAP

GREEN POWER

Code **4005**  
EAN 8050999570208  
Pack 1 pcs x 600 ml

Product details on page 123



### ULTRA DEGREASER

GREEN POWER

Code **3101**  
EAN 8032680393693  
Pack 1 pcs x 750 ml

Product details on page 74



### CRYSTAL

GREEN POWER

Code **3102**  
EAN 8032680393655  
Pack 1 pcs x 750 ml

Product details on page 74



### SURFACE

GREEN POWER

Code **3109-S**  
EAN 8054633837085  
Pack 1 pcs x 1000 ml

Product details on page 51



### IGIENIKAL

GREEN POWER

Code **3103**  
EAN 8032680393686  
Pack 1 pcs x 750 ml

Product details on page 66



### WCgel

GREEN POWER

Code **1945**  
EAN 8050999570703  
Pack 1 pcs x 700 ml

Product details on page 70



## DISINFECTION KIT

A complete line of disinfectant products according to **Italian Ministry of Health** to meet every professional need



Code **1006-S**  
EAN IC 18050999572032



### SECURGERM MED

Code **1027**  
EAN 8050999571618  
Pack 1 pcs x 1000 ml

Product details on page 128



### MULTI ACTIV

Code **1821-S**  
EAN 8032680391446  
Pack 1 pcs x 750 ml

Product details on page 33



### MULTI ACTIV

Code **1822-S**  
EAN 8032680392009  
Pack 1 pcs x 750 ml

Product details on page 34



### BAKTERIO

Code **1540N-S**  
EAN 8032680392719  
Pack 1 pcs x 1000 ml

Product details on page 59



### SANI ACTIVE

Code **1804-S**  
EAN 8054633834602  
Pack 1 pcs x 750 ml

Product details on page 33



### CHLOR WC GEL

Code **1944**  
EAN 8050999570697  
Pack 1 pcs x 700 ml

Product details on page 71

## BLUE CLOTH



Microfibre Cloth 38 x 38 cm

- Suitable for low-bacterial load areas for routine cleaning and dusting

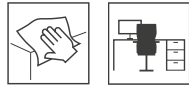

Cloth	Code	273
	EAN	8054633838389
	Pack	5 pcs - 38x38 cm

## RED CLOTH



Microfibre Cloth 38 x 38 cm

- Suitable for very high bacterial load areas for WCs, toilets and urinals



Cloth	Code	274
	EAN	8054633838396
	Pack	5 pcs - 38x38 cm

## YELLOW CLOTH



Microfibre Cloth 38 x 38 cm

- Suitable for high bacterial load bathroom areas



Cloth	Code	275
	EAN	8054633838402
	Pack	5 pcs - 38x38 cm

## GREEN CLOTH



Microfibre Cloth 38 x 38 cm

- Suitable for medium bacterial load areas for food surfaces and hospital environments



Cloth	Code	276
	EAN	8054633838419
	Pack	5 pcs - 38x38 cm





# Air fresheners

# The new professional odour neutralising detergents and air fresheners line

Thanks to innovative odour-eliminating technology and long-lasting fragrance - up to 48 hours in some formulations - the DEO line of professional odour neutralising detergents and air fresheners guarantee impeccable cleanliness and an olfactory experience that creates welcoming environments with a strong, recognisable and distinctive sensory identity.

Ideal for accommodations, restaurants, offices and business centres, DEO products transform the perception of spaces thanks to sophisticated fragrances that interpret the latest trends in the fragrance world, created in collaboration with prestigious *perfume houses*.

- **DEO SURFACE Multi-surface odour neutralising detergents** for floors and hard surfaces, with long-lasting fragrance, up to 24h
- **DEO FRESH air fresheners** for rooms with a persistent fragrance for up to 48h
- **DEO SPRAY air fresheners** for both rooms and fabrics, with fragrance lasting up to 48h



## FLORALS

Code 2204 | 2303 | 2304 | 2403

## FRESH FLORALS

Code 2200 | 2300 | 2400

## ORIENTAL WOODY

Code 2201 | 2301 | 2401

# Olfactory families

With Sanitec DEO, professional cleansing meets the art of perfumery. A range of six exclusive fragrances, developed in collaboration with prestigious perfume houses, to interpret the most popular olfactory trends and transform every room into a multi-sensory experience.

Ideal for the world of hospitality and facility management, Sanitec DEO responds to the growing focus on the sensory wellbeing and olfactory identity of spaces, offering a perceptive continuity between different environments, right down to the fabrics.

**With Sanitec DEO, every room has its own scent,  
each experience its own atmosphere**

**FLORAL & FRESH FLORALS:** elegance, lightness and refinement

**WOODY AROMATIC:** herbaceous freshness and professional cleaning

**WOODY ORIENTAL:** richness, warmth and depth

**CITRUS & FRUITY FLORAL:** vitality, energy and positivity



**AROMATIC WOODY**

Code 2203 | 2302



**CITRUS**

Code 2202 | 2402



**FRUITY FLORAL**

Code 2205 | 2305 | 2404

## DEO SURFACE

Multi-surface cleaner for floors and other hard surfaces, with odour-eliminating technology

- Cleans thoroughly
- Persistent fragrance up to **24h**
- Leaves surfaces shiny, without streaks

**Directions:** Dilute the product in water according to the directions. Apply the product diluted with a cloth, mop or scrubber. No rinsing required.

### Dosage:

Mop/scrubber cleaning:

For routine cleaning dilute the product to 1% (10 ml/L)

For a medium degree of soiling dilute the product to 2% (20 ml/L)

For stubborn soiling and for extra fragrance dilute the product to 3% (30 ml/L)

Cleaning with spray:

For routine cleaning dilute the product to 1% (10 ml/L)

For a medium degree of soiling dilute the product to 2% (20 ml/L)

Dosing cap capacity: 50 ml (without safety seal). Apply the product diluted with a cloth, mop or scrubber. No rinsing required. Add a capful of detergent for an even more intense fragrance.

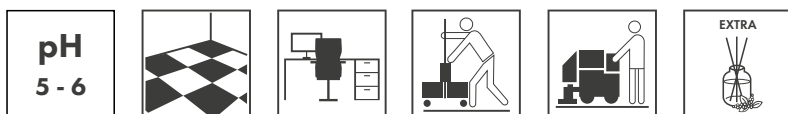

**White Musk**



**Gold argan**



Code **2200**  
 EAN 8050999572868  
 Pack 2 pcs x 5 L / 5 kg  
 Box x Lyr 18  
 Box x Plt 72



View the data sheet



Code **2201**  
 EAN 8050999572875  
 Pack 2 pcs x 5 L / 5 kg  
 Box x Lyr 18  
 Box x Plt 72



View the data sheet



**Fresh citrus**



Code **2202**  
 EAN 8050999572882  
 Pack 2 pcs x 5 L / 5 kg  
 Box x Lyr 18  
 Box x Plt 72



View the data sheet



**Pine & juniper**



Code **2203**  
 EAN 8050999572899  
 Pack 2 pcs x 5 L / 5 kg  
 Box x Lyr 18  
 Box x Plt 72



View the data sheet



**Flower bouquet**



Code **2204**  
 EAN 8050999572905  
 Pack 2 pcs x 5 L / 5 kg  
 Box x Lyr 18  
 Box x Plt 72



View the data sheet



**Peach & green apple**



Code **2205**  
 EAN 8050999572912  
 Pack 2 pcs x 5 L / 5 kg  
 Box x Lyr 18  
 Box x Plt 72



View the data sheet

**DEO FRESH**

Long-lasting air freshener with odour-eliminating technology

- Pleasantly scents rooms
- Persistent fragrance up to **48h**

**Directions:** Press the dispenser 2-3 times, directing the spray upwards into the corners of the room and at a distance of about 30 cm from surfaces.

**Dosage:** Ready to use.

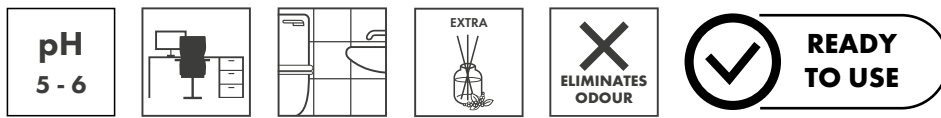

**White Musk**



**Gold argan**



Code **2300**  
 EAN 8050999572929  
 Pack 6 pcs x 750 ml  
 Box x Lyr 21  
 Box x Plt 105



View the data sheet



Code **2301**  
 EAN 8050999572936  
 Pack 6 pcs x 750 ml  
 Box x Lyr 21  
 Box x Plt 105



View the data sheet



**Pine & juniper**



Code **2302**  
 EAN 8050999572943  
 Pack 6 pcs x 750 ml  
 Box x Lyr 21  
 Box x Plt 105



View the data sheet



**Flower bouquet**



Code **2303**  
 EAN 8050999572950  
 Pack 6 pcs x 750 ml  
 Box x Lyr 21  
 Box x Plt 105



View the data sheet



**Iris**



Code **2304**  
 EAN 8050999572967  
 Pack 6 pcs x 750 ml  
 Box x Lyr 21  
 Box x Plt 105



View the data sheet



**Peach & green apple**



Code **2305**  
 EAN 8050999572974  
 Pack 6 pcs x 750 ml  
 Box x Lyr 21  
 Box x Plt 105



View the data sheet

## DEO SPRAY

Air and fabric freshener with odour-eliminating technology

- Pleasantly scents fabrics and rooms
- Persistent fragrance up to 48h
- No stain

**Directions:** Press the dispenser 2-3 times, directing the spray upwards into the corners of the room and at a distance of approximately 30 cm from surfaces and fabrics.

**Dosage:** Ready to use.

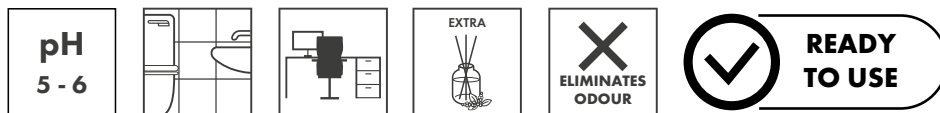

**White Musk**



**Gold argan**



Code **2400**  
 EAN 8050999573094  
 Pack 12 pcs x 300 ml  
 Box x Lyr 24  
 Box x Plt 144



View the data sheet



Code **2401**  
 EAN 8050999573100  
 Pack 12 pcs x 300 ml  
 Box x Lyr 24  
 Box x Plt 144



View the data sheet



**Bergamot and Jasmine**



Code **2402**  
 EAN 8050999573117  
 Pack 12 pcs x 300 ml  
 Box x Lyr 24  
 Box x Plt 144



View the data sheet



**Flower bouquet**



Code **2403**  
 EAN 8050999573124  
 Pack 12 pcs x 300 ml  
 Box x Lyr 24  
 Box x Plt 144



View the data sheet



**Peach & green apple**



Code **2404**  
 EAN 8050999573131  
 Pack 12 pcs x 300 ml  
 Box x Lyr 24  
 Box x Plt 144



View the data sheet





# Laundry



# Laundry

Cleaning fabrics in a professional environment is a key aspect to ensure the safety and comfort of customers. An efficient wash is one that not only effectively removes dirt, but also preserves the softness and integrity of fabrics over time. Type and colour of fabrics, water hardness conditions and the presence of heavy metals are some of the parameters that must be considered when selecting the optimal products and washing process.

Sanitec offers a wide range of detergents and pre-treatments for professional textile washing, with formulas carefully designed for various washing conditions

## PROCAPS TECHNOLOGY

Sanitec fabric softeners, thanks to Procaps technology, encapsulated fragrances with prolonged release, guarantee a long-lasting, persistent fragrance on damp and dry clothes.



## PRODUCTS

### X1 OXY REMOVER

Code 1814

### X2 GREASY REMOVER

Code 1816

### X3 SOLV REMOVER

Code 1817

### X4 RUST REMOVER

Code 1819

### QUANTUM BASIC

Code 2051HC and 2077HC - Ecolabel Certificate

### QUANTUM SURF

Code 2052HC and 2076HC - Ecolabel Certificate

### QUANTUM BOOSTER

Code 2090HC

### QUANTUM CHLOR

Code 2053HC and 2078HC

### QUANTUM PERACETIC

Code 2054HC and 2073HC

### QUANTUM OXYGEN

Code 2050HC and 2049HC - Ecolabel Certificate

### QUANTUM SOFT

Code 2065HC and Ecolabel Certificate, 2064HC, 2071HC, 2083HC

### LAUNDRY BASIC

Code 2077

### LAUNDRY SURF

Code 2076

### LAUNDRY SOFT

Code 2071, 2072

### LAUNDRY NEUTRALIZER

Code 2046

**PHASE 1**

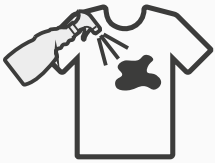

**PRE-TREATMENT**

Pretreatment is used in **conditions of particular dirt and difficult removal.**

The product is **applied directly to the stain** before putting it in the machine

**PHASE 2**



**PREWASH**

Prewash is used on **stubborn dirt conditions.**

The purpose of this phase is **to help separate fabric fibres and remove sticky substances**, to avoid them from setting in the subsequent stages.

**Pre-washing white clothes can also be done with a chlorine-based product**

< 40°C

4 - 8 min

**PHASE 3**



**WASHING**

The main wash has the task of **attacking, dissolving and suspending dirt** found on the fibres.

At this stage it is important to work with the correct level of **alkalinity to promote complete separation of the fibres** and allow the product and water to act more deeply, saponifying oils and greases and making them soluble in water

30 - 90 °C

12 - 18 min

**PHASE 4**

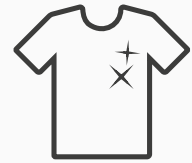

**RINSING**

Rinsing **removes any dirt still present and traces of detergent** from the fabrics. Usually at least 3 rinses are programmed.

In the final rinse the **acidification process** is carried out, which neutralizes the effect of the detergent by bringing the pH to neutral values.

This can be achieved **through a neutralizer or fabric softener**

Cold

3 cycles x 3 min

**PRE-TREATMENT**

**PREWASH**

**WASHING**

**RINSING**

- 
- 
- 
- 

- 
- 
- 
- 

- 
- 
- 
- 

- 

- 
- 

- 
- 

- 
-



# Quantum concentrated system

Sanitec Quantum is the **concentrated liquid product line** developed for the automatic washing of textiles in the professional sector. The comprehensive range of detergents, softeners and additives combines excellent performance with reduced environmental impact.

Within the Quantum line, an **Ecolabel system [EU ECOLABEL IT/039/009 Laundry Detergents for Industrial and Professional Use]** has been certified to meet the highest verified environmental requirements.

Thanks to the synergy between surfactants and enzymatic components, the system is designed to guarantee excellent results even at low temperatures so as to reduce costs and time associated with washing, preserve textiles for longer and contribute to the reduction of CO<sub>2</sub> emissions.

## Advantages of the Quantum system:



Reduction of storage space and transport and disposal costs



Products without EDTA and NTA



Reduced weight to be handled by the operator

## ECOLABEL-CERTIFIED SOLUTION



QUANTUM BASIC

+



QUANTUM SURF

+



QUANTUM OXYGEN

+



QUANTUM SOFT ECO  
Floral

## SOLUTIONS FOR COIN-OPERATED SELF-SERVICE LAUNDROMATS



QUANTUM SURF

+



QUANTUM PERACETIC

+



QUANTUM SOFT ECO  
Floral



QUANTUM SOFT  
Mediterranean Flowers  
Argan

**LAUNDRY SOLUTIONS FOR NURSING HOMES, HOSPITALS, HOTELS AND COMPANIES**



**SOLUTIONS FOR THE WASHING & MOP /FRINGE PRE-SOAKING FOR CLEANING COMPANIES**





## Laundry system

Sanitec's Laundry line offers a complete range of detergents and fabric softeners designed to ensure effective soil removal, prevent fabric greying, and deliver enhanced softness together with a long-lasting fragrance.

The combined use of products within the Laundry range enables excellent performance even at low washing temperatures.

### SOLUTIONS FOR COIN-OPERATED SELF-SERVICE LAUNDROMATS



**LAUNDRY SOLUTIONS FOR NURSING HOMES, HOSPITALS, HOTELS AND COMPANIES**



**SOLUTIONS FOR THE WASHING & MOP /FRINGE PRE-SOAKING FOR CLEANING COMPANIES**



# ProActive System technology

Quantum Surf and Quantum Booster were developed with the **ProActive System technology** which protects fabrics by facilitating the removal of dirt molecules and preventing redepositing during the washing phases.



## Helps remove dirt from the very first use



## Continuous use facilitates removal and prevents redeposition



**QUANTUM BASIC**



Concentrated alkaline sequestrant detergent

- Quantum System **Ecolabel-certified**, environmentally friendly
- Effectively removes dirt by increasing the alkalinity of the wash bath
- Avoids the redeposition of removed dirt on fibres due to formula with anti-redeposition agents
- Prevents greying of fabrics
- Suitable for delicate, coloured clothes and microfibre mops and cloths

**Directions:** For use with L-Brain Connect automatic dosing systems only. It must be used during the pre-wash or wash phase. For optimum results, we recommend using Quantum system products. Do not use on wool and delicates.

**Dosage:** 0,5-4 ml/kg of dry laundry. The recommended dosage refers to the use of the product under optimal conditions. Consult Sanitec Service technical support for dosage adjustment.



	Code	<b>2051HC</b>	Pcs x Box	2
	EAN	8032680390098	Box x Lyr	18
	Volume	5 L / 6.6 kg	Box x Plt	72



	Code	<b>2077HC</b>	Pcs x Box	1
	EAN	8054633835784	Box x Lyr	13
	Volume	15 L / 19.8 kg	Box x Plt	52



**LAUNDRY BASIC**



Alkaline sequestering fabric detergent

- Removes dirt by increasing the alkalinity of the wash bath
- Contains anti-redeposition agents that prevent redeposition of the removed dirt onto the fibres during washing
- Prevents greying of fabrics
- Non-foaming
- For use in combination with Laundry Surf

**Directions:** For use with L-Brain Connect automatic dosing systems only. It must be used during the pre-wash or wash phase.

**Dosage:** 4-12 ml/kg of dry laundry. The recommended dosage refers to the use of the product under optimal conditions. Consult Sanitec Service technical support for dosage adjustment.

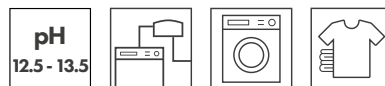

	Code	<b>2077</b>	Pcs x Box	1
	EAN	8054633830345	Box x Lyr	13
	Volume	15 L / 18.2 kg	Box x Plt	52



**QUANTUM SURF**



Concentrated stain removal detergent with enzymes and optical brighteners, for white and coloured fabrics

- Quantum System **Ecolabel-certified**, environmentally friendly
- Effectively removes greasy and enzymatic soiling. Provides excellent whiteness. Prevents greying of fabrics
- Formulated with **Proactive System** technology that protects fibres from the redeposition of dirt

**Directions:** For use with L-Brain Connect automatic dosing systems only. It must be used during the pre-wash or wash phase. For optimum results, we recommend using the Quantum system products

**Dosage:** 1-3 ml/kg of dry laundry. The recommended dosage refers to the use of the product under optimal conditions. Consult Sanitec Service technical support for dosage adjustment.



	Code	<b>2052HC</b>	Pcs x Box	2
	EAN	8032680390111	Box x Lyr	18
	Volume	5 L / 5.2 kg	Box x Plt	72



	Code	<b>2076HC</b>	Pcs x Box	1
	EAN	8054633835791	Box x Lyr	13
	Volume	15 L / 15.6 kg	Box x Plt	52

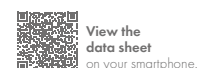

# AUTOMATIC DOSING

## LAUNDRY SURF | Floral



Enzymatic stain remover with optical whiteners

- Effectively removes greasy and enzymatic soiling
- Provides excellent whiteness
- Protects fibres from redeposition

**Directions:** For use with L-Brain Connect automatic dosing systems only. It must be used during the pre-wash or wash phase. For all types of fabric.

**Dosage:** 3-9 ml/kg of dry laundry. The recommended dosage refers to the use of the product under optimal conditions. Consult Sanitec Service technical support for dosage adjustment.



15 L	Code	2076	Pcs x Box	1
	EAN	8054633830338	Box x Lyr	13
	Volume	15 L / 15.5 kg	Box x Plt	52



View the data sheet on your smartphone.

## QUANTUM CHLOR

Product pending registration as **Biocide**



Active chlorine bleach for fabrics

- Cleans and sanitises
- High stain removal effectiveness on most fabrics
- Effective even at 30°C

**Directions:** For use with L-Brain Connect automatic dosing systems only. It must be used during the pre-wash or wash phase. For optimum results, we recommend using Quantum system products. For all fabric types resistant to chlorine bleaching.

**Dosage:** 3-10 ml/kg of dry laundry. The recommended dosage refers to the use of the product under optimal conditions. Consult Sanitec Service technical support for dosage adjustment



5 L	Code	2053HC	Pcs x Box	2
	EAN	8032680390180	Box x Lyr	18
	Volume	5 L / 6.3 kg	Box x Plt	72



View the data sheet on your smartphone.

15 L	Code	2078HC	Pcs x Box	1
	EAN	8054633835807	Box x Lyr	13
	Volume	15 L / 18.8 kg	Box x Plt	52



View the data sheet on your smartphone.

## QUANTUM OXYGEN



Concentrated active oxygen bleach for fabrics

- Quantum System **Ecolabel-certified**, environmentally friendly
- Effectively cleans fabrics, including colours.
- Can be used on all types of fabric
- Can also be used at temperatures above 60°C

**Directions:** For use with L-Brain Connect automatic dosing systems only. It must be used during the pre-wash or wash phase. Optimised for use with Quantum system products. For all white and coloured fabrics resistant to active oxygen bleaching.

**Dosage:** 2-10 ml/kg of dry laundry. The recommended dosage refers to the use of the product under optimal conditions. Consult Sanitec Service technical support for dosage adjustment.



5 L	Code	2050HC	Pcs x Box	2
	EAN	8032680390173	Box x Lyr	18
	Volume	5 L / 5.7 kg	Box x Plt	72



View the data sheet on your smartphone.

15 L	Code	2049HC	Pcs x Box	1
	EAN	8054633835777	Box x Lyr	13
	Volume	15 L / 17 kg	Box x Plt	52



View the data sheet on your smartphone.

## QUANTUM PERACETIC

Product pending registration as **Biocide**



Concentrated peracetic acid-based bleach for fabrics

- Removes stains effectively and is also suitable for coloured clothes
- Can be used on all types of fabric
- The best results are obtained at temperatures between 40-70 °C

**Directions:** Optimised for use with Quantum system products. For use with L-Brain Connect automatic dosing systems only. It must be used during the pre-wash or wash phase.

**Dosage:** 2-10 ml/kg of dry laundry. The recommended dosage refers to the use of the product under optimal conditions. Consult Sanitec Service technical support for dosage adjustment.

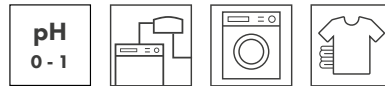

	Code	<b>2054HC</b>	Pcs x Box	2
	EAN	8032680392474	Box x Lyr	18
	Volume	5 L / 5.6 kg	Box x Plt	72



	Code	<b>2073HC</b>	Pcs x Box	1
	EAN	8054633835814	Box x Lyr	13
	Volume	15 L / 16.8 kg	Box x Plt	52



## QUANTUM BOOSTER



Surfactant- and solvent-based super stain removing additive for fabrics

- Effectively removes greasy dirt, grease, sunscreen, SPA oils, paint
- Protects fibres from dirt redeposition and facilitates removal thanks to **Proactive System** technology
- Optimised for use with Quantum system products

**Directions:** Optimised for use with Quantum system products. For use with L-Brain Connect automatic dosing systems only. It must be used during the pre-wash or wash phase.

**Dosage:** 2-5 ml/kg of dry laundry. The recommended dosage refers to the use of the product under optimal conditions. Consult Sanitec Service technical support for dosage adjustment.

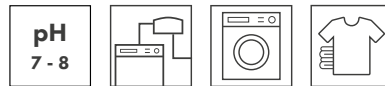

	Code	<b>2090HC</b>	Pcs x Box	2
	EAN	8054633837993	Box x Lyr	18
	Volume	5 L / 5 kg	Box x Plt	72



## QUANTUM SOFT ECO | Floral



Scented neutralising concentrated softener with odour-eliminating molecule

- Quantum System **Ecolabel-certified**, environmentally friendly
- Softer laundry thanks to a formulation that prevents the build-up of electrostatic charges on the fabric during drying and ironing
- Leaves a pleasant fragrance

**Directions:** Optimised for use with Quantum system products. For use with L-Brain Connect automatic dosing systems only. It must be used during the rinsing phase.

**Dosage:** 1-3 ml/kg of dry laundry. The recommended dosage refers to the use of the product under optimal conditions. Consult Sanitec Service technical support for dosage adjustment.



	Code	<b>2065HC</b>	Pcs x Box	2
	EAN	8054633839782	Box x Lyr	18
	Volume	5 L / 5 kg	Box x Plt	72



# AUTOMATIC DOSING

## QUANTUM SOFT | Mediterranean Flowers



Scented neutralising concentrated softener with odour-eliminating molecule

- Softer laundry thanks to a formulation that prevents the build-up of electrostatic charges on the fabric during drying and ironing
- Intense long-lasting fragrance thanks to **Procaps technology**
- With odour-eliminating molecule for odour treatment

**Directions:** Optimised for use with Quantum system products. For use with L-Brain Connect automatic dosing systems only. It must be used during the rinsing phase.

**Dosage:** 1-3 ml/kg of dry laundry. The recommended dosage refers to the use of the product under optimal conditions. Consult Sanitec Service technical support for dosage adjustment.

**pH**  
2.5 - 3.5



Code	<b>2064HC</b>	Pcs x Box	2
EAN	8032680390081	Box x Lyr	18
Volume	5 L / 5 kg	Box x Plt	72



View the data sheet on your smartphone.



Code	<b>2071HC</b>	Pcs x Box	1
EAN	8054633835821	Box x Lyr	13
Volume	15 L / 15 kg	Box x Plt	52



View the data sheet on your smartphone.

## QUANTUM SOFT | Argan



Scented neutralising concentrated softener with odour-eliminating molecule

- Softer laundry thanks to a formulation that prevents the build-up of electrostatic charges on the fabric during drying and ironing
- Intense long-lasting fragrance thanks to **Procaps technology**
- With odour-eliminating molecule for odour treatment

**Directions:** Optimised for use with Quantum system products. For use with L-Brain Connect automatic dosing systems only. It must be used during the rinsing phase.

**Dosage:** 1-3 ml/kg of dry laundry. The recommended dosage refers to the use of the product under optimal conditions. Consult Sanitec Service technical support for dosage adjustment.

**pH**  
2.5 - 3.5



Code	<b>2083HC</b>	Pcs x Box	2
EAN	8054633835746	Box x Lyr	18
Volume	5 L / 5 kg	Box x Plt	72



View the data sheet on your smartphone.

## LAUNDRY SOFT | Mediterranean Flowers



Scented neutralising concentrated softener with odour-eliminating molecule

- Softens fibres, preventing the build-up of electrostatic charges on the fabric during drying and ironing
- Long-lasting, persistent fragrance thanks to **Procaps technology**
- Eliminates odours thanks to the odour-eliminating molecule formula

**Directions:** For use with L-Brain Connect automatic dosing systems only. It must be used during the rinsing phase. For all types of fabric.

**Dosage:** 1-3 ml/kg of dry laundry. The recommended dosage refers to the use of the product under optimal conditions. Consult Sanitec Service technical support for dosage adjustment.

**pH**  
2.5 - 3.5



Code	<b>2071</b>	Pcs x Box	1
EAN	8054633830277	Box x Lyr	13
Volume	15 L / 15 kg	Box x Plt	52



View the data sheet on your smartphone.

## LAUNDRY SOFT | White Musk



Scented neutralising concentrated softener with odour-eliminating molecule

- Softens fibres, preventing the build-up of electrostatic charges on the fabric during drying and ironing
- Long-lasting, persistent fragrance thanks to **Procaps technology**
- Eliminates odours thanks to the odour-eliminating molecule formula

**Directions:** For use with L-Brain Connect automatic dosing systems only. It must be used during the rinsing phase. For all types of fabric.

**Dosage:** 1-3 ml/kg of dry laundry. The recommended dosage refers to the use of the product under optimal conditions. Consult Sanitec Service technical support for dosage adjustment.



15 L	Code	2072	Pcs x Box	1
	EAN	8054633830284	Box x Lyr	13
	Volume	15 L / 15 kg	Box x Plt	52



## LAUNDRY NEUTRALIZER | No fragrance



Acid alkalinity neutraliser

- Avoids the formation of yellow stains on fabrics after drying and ironing
- Restabilises natural pH of washed fabrics in the rinse phase
- Prevents limescale build-up inside the washing machine
- Fragrance-free

**Directions:** For use with L-Brain Connect automatic dosing systems only. It must be used during the rinsing phase. For all types of fabric.

**Dosage:** 2-8 ml/kg of dry laundry. The recommended dosage refers to the use of the product under optimal conditions. Consult Sanitec Service technical support for dosage adjustment.



15 L	Code	2046	Pcs x Box	1
	EAN	8054633835937	Box x Lyr	13
	Volume	15 L / 18 kg	Box x Plt	52



# L-BRAIN CONNECT ACCESSORIES

## L-BRAIN CONNECT CONTROL UNIT

Dosing system with six peristaltic pumps



- Suitable for washing machines from 7 to 100 kg
- Consistently delivers products without loss of washing performance
- Exclusive dedicated software with storage and processing of washing statistics and energy consumption

Control unit	Code	240
	EAN	-
	Volume	-

## TANK HOLDER BRACKET



Wall bracket for hanging the 5 L tank

- Tidier room
- Increased safety for operators

Wall bracket	Code	11847
	EAN	-
	Volume	1 pc

# Made-to-measure cleaning with L-Brain Connect

L-Brain Connect is an intelligent dosing control unit that, through a Wi-Fi connection, allows you to control the entire wash cycle, detect system function and monitor associated costs.



Dosing system with **six peristaltic pumps** suitable for all professional washing machines

It **consistently delivers concentrated products** without losing washing performance

Real-time verification of the system's and its components' operation



Wi-Fi connection for remote control from PC, tablet and smartphone

Statistics with data on energy consumption and cleaning costs



Entering and editing washing programs remotely

Continuously evolving and constantly updated software



Reduced technical support costs by at least 40%



Alerting the laundromat manager by e-mail when a tank of product is about to run out



Possibility of checking and managing the customer's product stock directly from the software and then reordering goods

**MALFUNCTIONS REDUCED TO ZERO**

**ASSISTANCE ONLY WHEN NEEDED**

**AUTOMATIC LOGISTICS MANAGEMENT**

## WASHDET GREEN POWER | Floral



**Ecolabel-certified** enzymatic concentrated detergent for washing all types of fabrics

- Low environmental impact
- Effective on even the most stubborn stains
- Complete product with surfactants and enzymes

**Directions:** Pour the product in and proceed with normal washing.

**Dosage:** 3-6 ml per kg of dry linen depending on the degree of soiling and water hardness, 50 ml per 4.5 kg of dry linen



Code	<b>3112</b>	Pcs x Box	2
EAN	8054633837948	Box x Lyr	18
Volume	5 L / 5.2 kg	Box x Plt	72



View the data sheet on your smartphone.

## WASHDET | White Musk



Complete enzymatic detergent for washing fabrics

- Effective on even the most stubborn stains
- Safe on white and coloured fabrics
- Can be used with automatic or manual dosing systems

**Directions:** Pour the product in and proceed with normal washing.

**Dosage:** 11-16 ml per kg of dry linen depending on the degree of soiling and water hardness, 50 ml per 4.5 kg of dry linen.



Code	<b>2025</b>	Pcs x Box	2
EAN	8032680391071	Box x Lyr	18
Volume	5 L / 5.1 kg	Box x Plt	72



View the data sheet on your smartphone.

## WASHDET | Rose petals



Complete enzymatic detergent for washing fabrics

- Effective on even the most stubborn stains
- Safe on white and coloured fabrics
- Can be used with automatic or manual dosing systems

**Directions:** Pour the product in and proceed with normal washing.

**Dosage:** 11-16 ml per kg of dry linen depending on the degree of soiling and water hardness, 50 ml per 4.5 kg of dry linen.



Code	<b>SN2026</b>	Pcs x Box	2
EAN	8050999574497	Box x Lyr	18
Volume	5 L / 5.1 kg	Box x Plt	72



View the data sheet on your smartphone.

## WASHDET | Blue Orchid



Complete enzymatic detergent for washing fabrics

- Effective on even the most stubborn stains
- Safe on white and coloured fabrics
- Can be used with automatic or manual dosing systems

**Directions:** Pour the product in and proceed with normal washing.

**Dosage:** 11-16 ml per kg of dry linen depending on the degree of soiling and water hardness, 50 ml per 4.5 kg of dry linen.



	Code	2034	Pcs x Box	2
	EAN	8054633837962	Box x Lyr	18
	Volume	5 L / 5.1 kg	Box x Plt	72



	Code	2038	Pcs x Box	1
	EAN	8054633837979	Box x Lyr	13
	Volume	15 L / 15.3 kg	Box x Plt	52



## WASHDET EXTRA | Floral



Complete enzymatic super degreasing detergent for washing fabric

- Quickly and effectively removes stubborn greasy stains from work overalls, uniforms and cloths
- Safe on white and coloured fabrics

**Directions:** Pour according to the recommended doses. For particularly dirty garments, it is recommended to first soak in warm water. Can be used with automatic or manual dosing systems.

**Dosage:** 11-16 ml per kg of dry linen depending on the degree of soiling and water hardness, 50 ml per 4.5 kg of dry linen.



	Code	2023	Pcs x Box	2
	EAN	8032680393532	Box x Lyr	18
	Volume	5 L / 5.2 kg	Box x Plt	72



## WOOLDET | Floral



Complete detergent for washing wool and coloured fabrics, suitable for delicate fabrics

- Mild liquid detergent for wool, silk, cashmere and delicate fabrics
- Does not alter colours and respects fabrics
- Formula with anti-felting
- Can be used with automatic or manual dosing systems

**Directions:** Pour according to the recommended doses. For particularly dirty garments, it is recommended to first soak in warm water.

**Dosage:** 15-25 ml per kg of dry linen depending on the degree of soiling and water hardness, 50 ml per 4.5 kg of dry linen.



	Code	2030	Pcs x Box	2
	EAN	8032680391132	Box x Lyr	18
	Volume	5 L / 5.1 kg	Box x Plt	72



# HAND DOSING

## SOFTDET GREEN POWER | Floral



Super concentrated neutralising softener

- Leaves laundry soft
- Reduces electrostatic charge build-up, preventing yellowing of fabrics
- Can be used with automatic or manual dosing systems

**Directions:** Pour according to the recommended dosage and proceed with normal washing.  
**Dosage:** 3-6 ml/kg dry linen, 30 ml per 4.5 g dry linen.



Code	<b>3110</b>	Pcs x Box	2
EAN	8054633837986	Box x Lyr	18
Volume	5 L / 5 kg	Box x Plt	72



View the data sheet on your smartphone.

## SOFTDET | White Musk



Concentrated scented softener with neutralising action, for all fabric types

- Intense fragrance
- Leaves all laundry soft
- Prevents yellowing of fabrics, reducing the accumulation of electrostatic charges

**Directions:** In the washing machine: pour into the washing tray or before the last rinse. By hand: pour the product into warm water and proceed with normal washing. Can be used with automatic or manual dosing systems.

**Dosage:** 5-8 ml/kg dry linen, 30 ml per 4.5 g dry linen.



Code	<b>2060</b>	Pcs x Box	2
EAN	8032680391118	Box x Lyr	18
Volume	5 L / 5 kg	Box x Plt	72



View the data sheet on your smartphone.

## SOFTDET | Rose petals



Concentrated scented softener with neutralising action, for all fabric types

- Intense fragrance
- Leaves all laundry soft
- Prevents yellowing of fabrics, reducing the accumulation of electrostatic charges

**Directions:** In the washing machine: pour into the washing tray or before the last rinse. By hand: pour the product into warm water and proceed with normal washing. Can be used with automatic or manual dosing systems.

**Dosage:** 5-8 ml/kg dry linen, 30 ml per 4.5 g dry linen.



Code	<b>SN2062</b>	Pcs x Box	2
EAN	8050999574480	Box x Lyr	18
Volume	5 L / 5 kg	Box x Plt	72



View the data sheet on your smartphone.

## SOFTDET | Blue Orchid



Concentrated scented softener with neutralising action, for all fabric types

- Intense fragrance
- Leaves all laundry soft
- Prevents yellowing of fabrics, reducing the accumulation of electrostatic charges

**Directions:** In the washing machine: pour into the washing tray or before the last rinse. By hand: pour the product into warm water and proceed with normal washing. Can be used with automatic or manual dosing systems.

**Dosage:** 5-8 ml/kg dry linen, 30 ml per 4.5 g dry linen.

pH 2.5 - 3.5						<b>NO HAZARD PICTOGRAMS</b>
-----------------	--	--	--	--	--	-----------------------------

	Code	<b>2091</b>	Pcs x Box	2
	EAN	8054633838181	Box x Lyr	18
	Volume	5 L / 5 kg	Box x Plt	72



	Code	<b>2092</b>	Pcs x Box	1
	EAN	8054633838198	Box x Lyr	13
	Volume	15 L / 15 kg	Box x Plt	52



## ATOMIC ULTRA | Floral



Atomised, concentrated, enzymatic powder detergent with bleaching agents for all fabric types

- Effective on even the most stubborn stains
- Excellent results even at low temperatures
- Safe on white and coloured fabrics
- Complete product with surfactants, enzymes, bleaches and TAED

**Directions:** Dose the product and proceed with normal washing.

**Dosage:** 10-20 g/kg of dry laundry depending on the degree of soiling and water hardness.

pH 10.5 - 11.5			
-------------------	--	--	--

	Code	<b>2086</b>	Pcs x Box	1
	EAN	8050999573551	Box x Lyr	6
	Volume	12 kg	Box x Plt	60



## ATOMIC POWER | Lavender



Atomised powder detergent with bleach, for all types of fabric

- Effective on even the most stubborn stains
- Complete product with surfactants and bleaches
- Safe on white and coloured fabrics

**Directions:** Dose the product and proceed with normal washing.

**Dosage:** 10-20 g/kg of dry laundry depending on the degree of soiling and water hardness.

pH 10.5 - 11.5			
-------------------	--	--	--

	Code	<b>2087</b>	Pcs x Box	1
	EAN	8050999573568	Box x Lyr	6
	Volume	12 kg	Box x Plt	60



# PRETREATMENTS

## X1 OXY REMOVER | Marseille



Active oxygen-based pre-treatment for pigmented dirt and oxidisable stains

- Effectively removes oxidisable stains such as tea, coffee, wine, blood, fruit, grass, ice cream, tomato, mould
- Reduces waste rate and contributes to longer linen life avoiding continuous re-washing
- Safe on all types of fabrics, white and coloured

**Directions:** Pour the product directly onto the stain and let it sit for 5 to a maximum of 15 minutes. If necessary, use a brush to rub the product onto the stain. Dampen the stain with cold water and then put it in the washing machine with the usual washing programme used for the type of pre-treated fabric.

**Dosage:** Ready to use.

pH  
3.5 - 4.5



Code	1814	Pcs x Box	6
EAN	8054633830604	Box x Lyr	26
Volume	500 ml	Box x Plt	130



View the data sheet on your smartphone.

## X2 GREASE REMOVER | Marseille



Enzymatic pre-treatment for grease and protein soiling

- Effectively removes grease and protein stains such as egg, chocolate, cream, ice cream, milk, mayonnaise, sweat
- Reduces waste rate and contributes to longer linen life avoiding continuous re-washing
- Safe on all types of fabrics, white and coloured

**Directions:** Pour the product directly onto the stain and let it sit for 5 to a maximum of 15 minutes. If necessary, use a brush to rub the product onto the stain. Dampen the stain with cold water and then put it in the washing machine with the usual washing programme used for the type of pre-treated fabric.

**Dosage:** Ready to use.

pH  
9.5 - 10.5



Code	1816	Pcs x Box	6
EAN	8054633830611	Box x Lyr	26
Volume	500 ml	Box x Plt	130



View the data sheet on your smartphone.

## X3 SOLV REMOVER



Pre-treatment for solvent-based oil and ink stains

- Effectively removes stains such as ink, oil, wax, coal, tar, cosmetics, shoe polish, resins, paint
- Reduces waste rate and contributes to longer linen life avoiding continuous re-washing
- Safe on all types of fabrics, white and coloured

**Directions:** Pour the product directly onto the stain and let it sit for 5 to a maximum of 15 minutes. If necessary, use a brush to rub the product onto the stain. Dampen the stain with cold water and then put it in the washing machine with the usual washing programme used for the type of pre-treated fabric.

**Dosage:** Ready to use.

pH  
10.5 - 11.5



Code	1817	Pcs x Box	6
EAN	8054633830628	Box x Lyr	26
Volume	500 ml	Box x Plt	130



View the data sheet on your smartphone.

## X4 RUST REMOVER



Pre-treatment for rust stains and ferrous residues

- Effectively removes stains such as rust, mineral oxides, residues of cement, copper pesticide
- Reduces waste rate and contributes to longer linen life avoiding continuous re-washing
- Safe on all types of fabrics, white and coloured

**Directions:** Pour the product directly onto the stain and let it sit for 5 to a maximum of 15 minutes. If necessary, use a brush to rub the product onto the stain. Dampen the stain with cold water and then put it in the washing machine with the usual washing programme used for the type of pre-treated fabric.

**Dosage:** Ready to use.

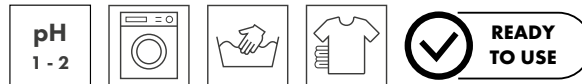

Code	1819	Pcs x Box	6
EAN	8054633830635	Box x Lyr	26
Volume	500 ml	Box x Pft	130



View the data sheet on your smartphone.

## STAIN REMOVAL GUIDE

	OXY REMOVER	GREASE REMOVER	SOLV REMOVER	RUST REMOVER
Drinks	•			
Egg		•		
Fruit	•			
Sauces and dips*	2	1		
Fat - grease - oil			•	
Glue and adhesive			•	
Ink and wax crayons			•	
Paint			•	
Shoe polish			•	
Resins			•	
Tar			•	
Oxidised metal				•
Rust				•
Grass and mud*	2	1	3	
Verdigris				•
Cosmetics			•	
Sunscreens		•	•	
Creams and ointments*		1	2	
Medicines*	2	1		
Blood		•		
Sweat		•		
Urine*	2	1		



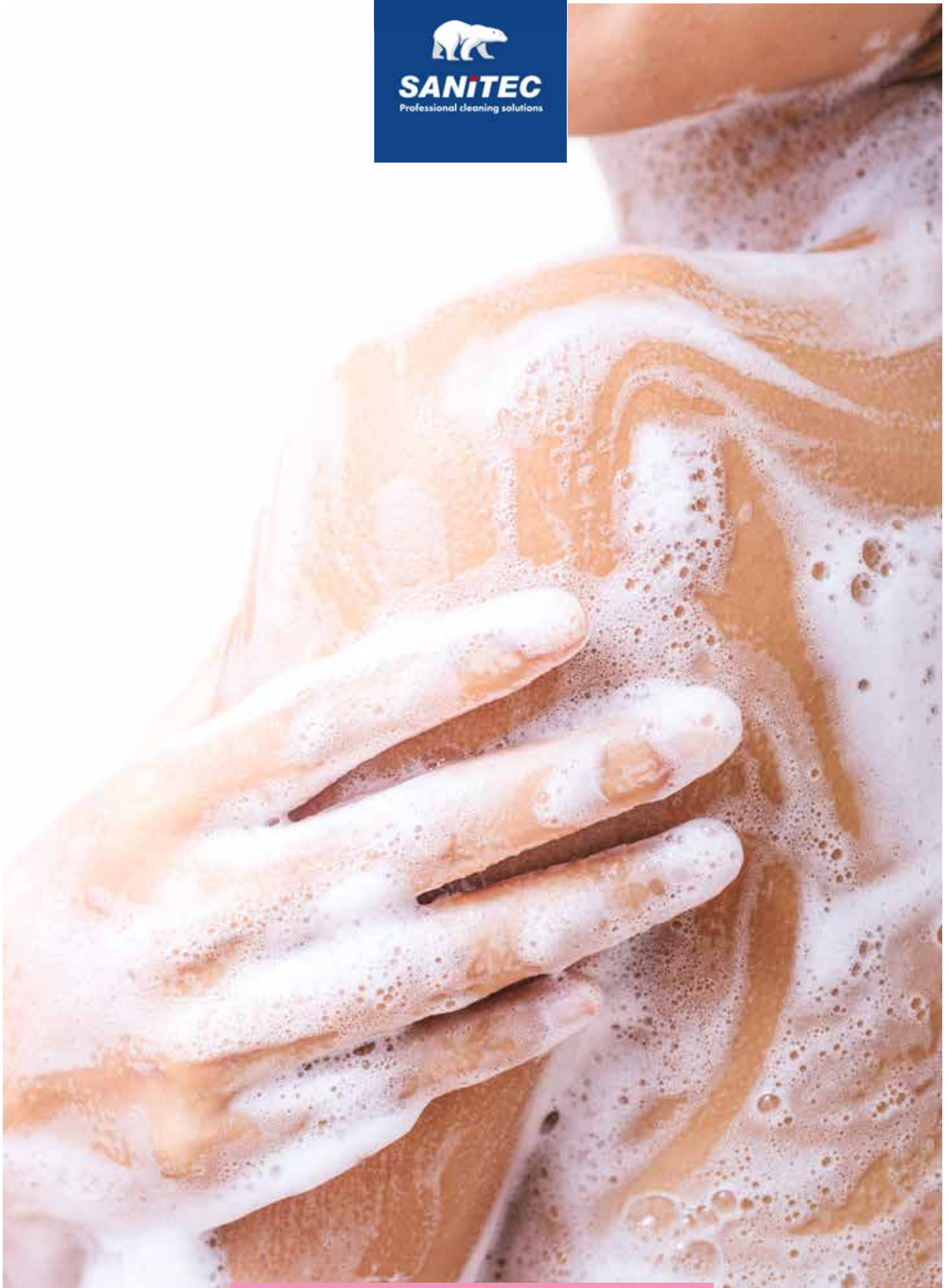

# Skin care

# Professional cosmetic solutions

Skin Laboratories is Sanitec's line of products dedicated to the care of all skin types, even the most sensitive. Ideal for residential care facilities, nursing homes, outpatient clinics and any other public or private healthcare facility.

The range offers specific formulas developed to meet different needs according to patient requirements.

## Active ingredients according to patient needs

### ZINC OXIDE

For a soothing action

It contributes to the regeneration of the epidermis by counteracting redness and erythema. It provides relief in the case of nappy rash in children, but also in the case of skin problems in adults or pressure sores in the elderly.

### GLYCERIN

For a moisturising, emollient, hygroscopic, refreshing action

Thanks to its humectant and hygroscopic properties, it is able to absorb the humidity present in the air, increasing the skin's hydration state. IT IS a fundamental ingredient for all products that combat skin dehydration and that aim to provide an immediate sensation of relief.

### PANTHENOL

For a moisturising, emollient and soothing action

Precursor of vitamin B (provitamin B5), it improves the barrier function of the skin by giving it elasticity and keeps it soft by aiding cell turnover. It has soothing, antiinflammatory and regenerative properties.

### MACADAMIA OIL

For an emollient and elasticising action

It restores moisture and softness to dry and irritated skin. It has strong antioxidant and elasticising properties.

## LIQUID SOAP GREEN POWER | Floral



**Ecolabel-certified** scented liquid soap with ingredients of natural origin

- EU Ecolabel-certified product with low environmental impact
- Gently cleanses hands and body
- Dermatologically tested

**Directions:** Apply the product to moistened hands. Rub until a soft lather is obtained, taking care to rub the spaces between the fingers and also the wrists for about 30 seconds. Rinse with water. Dry thoroughly.  
**Dosage:** Ready to use.



	Code	<b>4015</b>	Pcs x Box	6
	EAN	8054633831045	Box x Lyr	15
	Volume	1000 ml	Box x Plt	90



	Code	<b>4006</b>	Pcs x Box	2
	EAN	8032680394393	Box x Lyr	18
	Volume	5 L / 5.1 kg	Box x Plt	72



## MOUSSE SOAP GREEN POWER | Floral



Scented soap mousse for daily cleaning of hands and body, **Ecolabel-certified**, with ingredients of natural origin

- EU Ecolabel-certified product with low environmental impact
- Gently cleanses hands and body
- Dermatologically tested

**Directions:** Apply the product to moistened hands. Rub between the fingers and also the wrists for about 30 seconds. Rinse with water. Dry thoroughly.  
**Dosage:** Ready to use.



	Code	<b>4005</b>	Pcs x Box	6
	EAN	8050999570208	Box x Lyr	20
	Volume	600 ml	Box x Plt	120



	Code	<b>1091</b>	Pcs x Box	2
	EAN	8050999570192	Box x Lyr	18
	Volume	5 L / 5.1 kg	Box x Plt	72



## MOUSSE SOAP GREEN POWER | Floral



Scented soap mousse for daily cleaning of hands and body, **Ecolabel-certified**, with ingredients of natural origin

- EU Ecolabel-certified product with low environmental impact
- Gently cleanses hands and body
- Dermatologically tested

**Directions:** Pour into the appropriate bottle. Then apply the product to moistened hands with the dispenser. Rub between the fingers and also the wrists for about 30 seconds. Rinse with water and dry.  
**Dosage:** Ready to use.

Product compatible with **manual dispenser code 265** or **automatic code 266** on p. 125



	Code	<b>1061</b>	Pcs x Box	6
	EAN	8032680397387	Box x Lyr	14
	Volume	800 ml	Box x Plt	84



# HAND CLEANSERS

## CREAM SOAP | Green Aloe



Moisturising scented soap cream with antibacterial agents

- Cleanses hands leaving them fresh and clean
- With glycerine and antibacterial agents to protect and moisturise the skin
- Dermatologically tested, suitable for even the most sensitive skin
- With pH 5.5 it is gentle on the skin

**Directions:** Apply the product to moistened hands. Rub until a soft lather is obtained, taking care to rub the spaces between the fingers and also the wrists for about 30 seconds. Rinse with water. Dry thoroughly.

**Dosage:** Ready to use.



Code	<b>1080</b>	Pcs x Box	6
EAN	8054633837917	Box x Lyr	15
Volume	1000 ml	Box x Plt	90



View the data sheet on your smartphone.



Code	<b>1081</b>	Pcs x Box	2
EAN	8054633837924	Box x Lyr	18
Volume	5 L / 5.2 kg	Box x Plt	72



View the data sheet on your smartphone.

## CREAM SOAP | Blue Iris



Moisturising scented soap cream with antibacterial agents

- Cleanses hands leaving them fresh and clean
- With glycerine and antibacterial agents to protect and moisturise the skin
- Dermatologically tested, suitable for even the most sensitive skin
- With pH 5.5 it is gentle on the skin

**Directions:** Apply the product to moistened hands. Rub until a soft lather is obtained, taking care to rub the spaces between the fingers and also the wrists for about 30 seconds. Rinse with water. Dry thoroughly.

**Dosage:** Ready to use.



Code	<b>1020</b>	Pcs x Box	6
EAN	8032680397523	Box x Lyr	15
Volume	1000 ml	Box x Plt	90



View the data sheet on your smartphone.



Code	<b>1021</b>	Pcs x Box	2
EAN	8032680391026	Box x Lyr	18
Volume	5 L / 5.2 kg	Box x Plt	72



View the data sheet on your smartphone.

## CREAM SOAP | Golden Argan



Moisturising scented soap cream with antibacterial agents

- Cleanses hands leaving them fresh and clean
- With glycerine and antibacterial agents to protect and moisturise the skin
- Dermatologically tested, suitable for even the most sensitive skin
- With pH 5.5 it is gentle on the skin

**Directions:** Apply the product to moistened hands. Rub until a soft lather is obtained, taking care to rub the spaces between the fingers and also the wrists for about 30 seconds. Rinse with water. Dry thoroughly.

**Dosage:** Ready to use.



Code	<b>2018</b>	Pcs x Box	2
EAN	8054633830673	Box x Lyr	18
Volume	5 L / 5.2 kg	Box x Plt	72



View the data sheet on your smartphone.

HAND WASH | Shea



Scented liquid soap

- Cleanses hands leaving them fresh and clean
- With pH 5.5 it is gentle on the skin

**Directions:** Apply the product to moistened hands. Rub until a soft lather is obtained, taking care to rub the spaces between the fingers and also the wrists for about 30 seconds. Rinse with water. Dry thoroughly.

**Dosage:** Ready to use.

pH 5 - 6



	Code	1050	Pcs x Box	2
	EAN	8032680392023	Box x Lyr	18
	Volume	5 L / 5.2 kg	Box x Plt	72



SOAP AND GEL DISPENSER



Refill soap and gel dispenser

**Size:**

Height: 257 mm

Width: 130 mm

Depth: 114 mm

**Dosage:** One dose is equivalent to 0.8 - 1 ml of product

Manual dispenser	Code	247	Pcs x Box	1
	EAN	8054633837740	Box x Lyr	1
	Volume	-	Box x Plt	336

Automatic dispenser	Code	249	Pcs x Box	1
	EAN	8054633837764	Box x Lyr	1
	Volume	-	Box x Plt	336

MOUSSE SOAP DISPENSER



Mousse soap dispenser

**Size:**

Height: 257 mm

Width: 130 mm

Depth: 114 mm

**Dosage:** One dose is equivalent to 0.4 - 0.6 ml of product

Manual dispenser	Code	265	Pcs x Box	1
	EAN	8054633838075	Box x Lyr	1
	Volume	-	Box x Plt	336

Automatic dispenser	Code	266	Pcs x Box	1
	EAN	8054633838082	Box x Lyr	1
	Volume	-	Box x Plt	336

## SANI GEL MED



Alcohol-based hand sanitizer without rinsing, according to **Italian Ministry of Health**, Registration no. 20832

- Hydroalcoholic disinfectant for skin antiseptis
- Eliminates 99.9% of bacteria, fungi and viruses within 60 seconds
- With moisturising agents
- It can be used in any environment: healthcare, institutional, industrial and domestic

**Directions:** Dose the product on the palm in a quantity suitable for rubbing for at least 60 seconds, distributing it over all parts of the hand. The product is used without water and does not need to be rinsed.

**Dosage:** Ready to use. For surgical hand disinfection, apply the product for 180 seconds, spreading it evenly over the entire hand and forearm.

Support accessories on page 127

pH 6 - 7





Code	<b>1035</b>	Pcs x Box	6
EAN	8054633839423	Box x Lyr	20
Volume	600 ml	Box x Plt	140



View the data sheet on your smartphone.



Code	<b>1036</b>	Pcs x Box	2
EAN	8054633839430	Box x Lyr	18
Volume	5 L / 4.4 kg	Box x Plt	72



View the data sheet on your smartphone.



**Product code** 1035, 1036

**Active ingredient** Ethanol 70.1 g/100g

### Bactericidal efficacy

### Fungicidal efficacy

### Virucidal efficacy

#### Regulation

UNI EN 13727: 2015  
UNI EN 1500: 2013

UNI EN 13624: 2013

UNI EN 14476:2019

#### Tested organisms

Pseudomonas aeruginosa  
Staphylococcus aureus  
Enterococcus hirae  
Escherichia coli K12

Candida albicans  
Aspergillus brasiliensis

Adenovirus type 5,  
Murine norovirus MNV  
Poliovirus

#### Conditions of use

Concentration: ready to use  
Contact time: 60 seconds

Concentration: ready to use  
Contact time: 60 seconds

Concentration: ready to use  
Contact time: 60 seconds

**STAND FOR AUTOMATIC DISPENSER**



Stand with drip catcher for automatic refill or bag dispenser

**Stand dimensions:**

Height: 1440 mm  
 Base width: 300 mm  
 Base depth: 325 mm

Stand code **318** for use with automatic soap and gel dispenser code **249**

Stand	Code	<b>318</b>	Pcs x Box	1
	EAN	8054633831649	Box x Lyr	1
	Volume	-	Box x Plt	102

Automatic dispenser	Code	<b>249</b>	Pcs x Box	1
	EAN	8054633837764	Box x Lyr	1
	Volume	-	Box x Plt	336

**BOTTLE STAND**



Stand with anti-theft and drip-proof support for 600 ml gel bottle

**Stand dimensions:**

Height: 1440 mm  
 Base width: 300 mm  
 Base depth: 325 mm

**Size of anti-shoplifting support:**

Height: 163 mm  
 Width: 115 mm  
 Depth: 86 mm

Stand code **318** to be used with dropper dispenser for 600 ml gel bottle code **317**

Stand	Code	<b>318</b>	Pcs x Box	1
	EAN	8054633831649	Box x Lyr	1
	Volume	-	Box x Plt	102

Drip tray support	Code	<b>317</b>	Pcs x Box	1
	EAN	8054633839157	Box x Lyr	60
	Volume	-	Box x Plt	240

**WALL BRACKET FOR BOTTLE**



Wall bracket for 600 ml bottle, can be attached to the wall using the double-sided adhesive strips or with holes in the metal bracket

**Size:**

Height: 163 mm  
 Width: 95 mm  
 Depth: 68 mm

Manual dispenser	Code	<b>306A</b>	Pcs x Box	1
	EAN	8054633839010	Box x Lyr	100
	Volume	-	Box x Plt	400

## SECURGERM MED



Hand sanitizer soap, according to **Italian Ministry of Health**, Registration no. 21457

- Handwash disinfectant for use whenever thorough skin disinfection is required
- Eliminates 99.9% of bacteria and yeasts

**Directions:** Dose the product on the palm of the hand and wash for 60 seconds. Rinse thoroughly and dry.  
**Dosage:** Ready to use.

pH 5 - 6





	Code   <b>1027</b>	Pcs x Box   6
	EAN   8050999571618	Box x Lyr   15
	Volume   1000 ml	Box x Pkt   90



	Code   <b>1028</b>	Pcs x Box   2
	EAN   8050999571625	Box x Lyr   18
	Volume   5 L / 5 kg	Box x Pkt   72



**Product code** 1027, 1028

**Active ingredient** Alkyl dimethylbenzyl ammonium chloride 0.75 g  
100 g - 2-phenoxyethanol 0.9 g / 100 g

**Bactericidal efficacy**

**Fungicidal efficacy**

**Virucidal efficacy**

**Regulation**

EN 13727:2012+A2:2015  
EN 1499:2013

EN 13624:2013

14476:2013 + A2:2019

**Tested organisms**

Pseudomonas aeruginosa  
Staphylococcus aureus  
Escherichia coli K12  
Salmonella enterica  
Listeria monocytogenes  
Proteus mirabilis

Candida albicans  
Aspergillus brasiliensis

Modified Vaccinia virus Ankara

**Conditions of use**

Concentration: Ready to use  
Contact time: 5 minutes  
Dirt conditions

Concentration: Ready to use  
Contact time: 15 minutes  
Dirt conditions

Concentration: Ready to use  
Contact time: 15 minutes  
Dirt conditions

## SECURGERM SOFT MOUSSE



Soft, sanitising hand soap mousse with anti-bacterial agents

- Fragrance-free
- Dermatologically tested

**Directions:** Apply the product to moistened hands. Rub between the fingers and also the wrists for about 30 seconds. Rinse with water. Dry thoroughly.

**Dosage:** Ready to use.

pH 5 - 6





	Code   <b>1029</b>	Pcs x Box   6
	EAN   8050999570581	Box x Lyr   20
	Volume   600 ml	Box x Pkt   120



## INDUSTRIAL SOAP | Citrus



Specific liquid soap for stubborn dirt

- Excellent emulsifying power of mechanical oils and greases thanks to a formula with a high concentration of oleic acid
- Ideal for the industrial, mechanical and steel sectors

**Directions:** Apply the product to moistened hands. Rub until a soft lather is obtained, taking care to rub the spaces between the fingers and also the wrists for about 30 seconds. Rinse with water. Dry thoroughly.

**Dosage:** Ready to use.



Code	1040	Pcs x Box	6
EAN	8032680397547	Box x Lyr	15
Volume	1000 ml	Box x Plt	90



View the data sheet on your smartphone.

## INDUSTRIAL SOAP | Lemon



Specific liquid soap for stubborn dirt with scrub microgranules

- Contains biodegradable natural cellulose microgranules for more effective removal of dirt
- Excellent emulsifying power of mechanical oils and greases
- Ideal for the industrial, mechanical and steel sectors

**Directions:** Apply the product to moistened hands. Rub until a soft lather is obtained, taking care to rub the spaces between the fingers and also the wrists for about 30 seconds. Rinse with water. Dry thoroughly.

**Dosage:** Ready to use.

Each box contains 1 pc. **Dispenser for 5L can code I2388** description below



Code	1045	Pcs x Box	2
EAN	8032680391262	Box x Lyr	18
Volume	5 L / 4.7 kg	Box x Plt	72



View the data sheet on your smartphone.

## 5L CAN DISPENSER



Dispensing pump

- Precise, fast and safe
- Ensures hygiene and practicality

Manual dispenser	Code	I2388
	EAN	-
	Volume	-

# BODY CLEANSERS

## TOTAL BODY | Green tea



Gentle, low-foaming hair and body cleanser

- Ideal for complete daily hygiene also in the case of assisted cleansing
- With glycerine featuring emollient properties
- Dermatologically tested
- Suitable for all skin types, even the most sensitive

**Directions:** Apply the product to the palm of the hand or directly to the affected areas. Use it like a normal hand and body cleanser or shampoo. Alternatively, dilute it in water and proceed to use.

**Dosage:** Ready to use.

pH 4.5 - 5.5

FOR SENSITIVE SKIN

DERMATOLOGICALLY TESTED

READY TO USE

	Code	<b>3210</b>	Pcs x Box	6
	EAN	8050999570284	Box x Lyr	20
	Volume	500 ml	Box x Plt	140



View the data sheet on your smartphone.

	Code	<b>6030</b>	Pcs x Box	6
	EAN	8050999570062	Box x Lyr	15
	Volume	1000 ml	Box x Plt	90



View the data sheet on your smartphone.

## TOTAL BODY SOFT MOUSSE | Green tea



Soft, pH-neutral dermo-cleansing mousse with mild surfactants for the whole body, hair and intimate hygiene. With hyaluronic acid, glycerine, vitamin E and panthenol.

- Gently cleanses even the most sensitive areas thanks to its light texture, which allows non-abrasive cleansing with reduced rubbing and improved rinsing
- Free of sensitising preservatives, parabens, dyes, salt, EDTA, silicones, PEGs, paraffins and latex
- Mild fragrance (free of allergens listed in Annex III of EC Reg. 1223/2009) for a fresh feeling

**Directions:** Apply the product to the palm of the hand or with a cloth to the affected areas. Use it like a normal hand, body, intimate or shampoo cleanser, dosing it appropriately according to the area to be cleansed. Remove impurities and, depending on use, rinse with water.

**Dosage:** Ready to use.

pH 4.5 - 5.5

FOR SENSITIVE SKIN

DERMATOLOGICALLY TESTED

READY TO USE

	Code	<b>3211</b>	Pcs x Box	6
	EAN	8050999570659	Box x Lyr	20
	Volume	600 ml	Box x Plt	120



View the data sheet on your smartphone.

## SOFT SHOWER GEL | Green tea



Low-foaming body cleanser with Provitamin B5

- Respects the skin's natural hydrolipid film
- Leaves a low-lathering, non-greasy oil effect on the skin
- Dermatologically tested, suitable even for the most sensitive skin

**Directions:** Apply and massage the product onto damp skin and rinse thoroughly.

**Dosage:** Ready to use.

pH 4.5 - 5.5

FOR SENSITIVE SKIN

DERMATOLOGICALLY TESTED

READY TO USE

	Code	<b>6012</b>	Pcs x Box	6
	EAN	8050999570482	Box x Lyr	20
	Volume	600 ml	Box x Plt	140



View the data sheet on your smartphone.

**SOFT SHAMPOO** | Green tea



Gentle shampoo with Panthenol and Keratin, for frequent use

- Deeply cleanses all hair types
- With Panthenol and Keratin
- Also ideal for scalp disorders
- Dermatologically tested

**Directions:** Apply the product to wet hair then massage in gently. Leave on for a few moments and rinse. If necessary, repeat the operation.

**Dosage:** Ready to use.



	Code	<b>6013</b>	Pcs x Box	6
	EAN	8050999570499	Box x Lyr	20
	Volume	600 ml	Box x Plt	140



**CLEANSING OIL** | Green tea



Cleansing bath oil

- Cleanses while respecting the natural hydrolipid film
- It leaves an oil effect on the skin, non-foaming, non-greasy.
- Dermatologically tested, suitable for even the most sensitive skin
- With emollient and moisturising ingredients

**Directions:** Dilute the product in water, cleanse and rinse.

**Dosage:** Ready to use



	Code	<b>6031</b>	Pcs x Box	12
	EAN	8050999570116	Box x Lyr	14
	Volume	300 ml	Box x Plt	112



**INTIMATE WASH** | Green tea



Mild intimate cleanser with glycerine and lactic acid

- Respects the balance of bacterial flora and contributes to odour prevention
- Dermatologically tested, suitable for even the most sensitive skin

**Directions:** Apply the product directly to the palm of the hand and use it like a normal cleanser on the external intimate areas. Alternatively, dilute it in water and proceed to use. Intimate cleanser for external use.

**Dosage:** Ready to use



	Code	<b>6014</b>	Pcs x Box	12
	EAN	8050999570512	Box x Lyr	14
	Volume	250 ml	Box x Plt	112

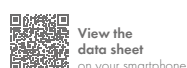

## BODY CREAMS

### WASH CREAM | Green tea



Cleansing cream with hydrating active ingredients for cleansing the entire body.

- Cleanses while maintaining the hydrolipidic balance of the skin
- Formula rich in active ingredients: with liquorice extract (glycyrrhethinic acid) - soothing/anti-inflammatory activity, with glycerine - moisturising, with coconut oil - emollient, with vitamin e - antioxidant activity, with food-grade preservatives
- Also suitable for assisted cleansing of bedridden persons, or as an alternative to wet wipes
- Dermatologically tested, suitable for even the most sensitive skin

**Directions:** Apply with a cloth or handpiece to the affected areas, leave for a few seconds and then remove the impurities. No rinsing required.

**Dosage:** Ready to use.



Code	6010	Pcs x Box	6
EAN	8054633839805	Box x Lyr	20
Volume	600 ml	Box x Plt	140



View the data sheet on your smartphone.

### SOFT EMULSION | Green tea



Moisturising and nourishing body cream

- Formula rich in active ingredients: with liquorice extract (glycyrrhethinic acid) - soothing/anti-inflammatory activity, with glycerine - moisturising, with coconut oil - emollient, with vitamin e - antioxidant activity, with food-grade preservatives
- Dermatologically tested, suitable for even the most sensitive skin

**Directions:** Apply with a cloth or handpiece to the affected areas, leave for a few seconds and then remove the impurities. No rinsing required.

**Dosage:** Ready to use.



Code	6011	Pcs x Box	6
EAN	8050999570055	Box x Lyr	20
Volume	600 ml	Box x Plt	140



View the data sheet on your smartphone.

### PRECIOUS OIL | Green tea



Emollient and elasticising body oil, with argan oil

- Also ideal for thin and delicate skin
- Dermatologically tested, suitable for even the most sensitive skin
- Mineral oil- and paraffin-free

**Directions:** Apply to the body and massage in circular movements until partially absorbed.

**Dosage:** Ready to use.



Code	6033	Pcs x Box	12
EAN	8050999570161	Box x Lyr	24
Volume	300 ml	Box x Plt	144



View the data sheet on your smartphone.

**BARRIER CREAM** | Green tea

Barrier body cream with 10% Zinc Oxide for soothing and hydrating action



- Protects the skin from external irritants, thanks to the action of Zinc oxide, which has antibacterial properties
- Dermatologically tested
- Suitable even for the most sensitive skin

**Directions:** Apply the required amount of product evenly to the affected areas

**Dosage:** Ready to use.



	<b>Code</b>	<b>6020</b>	<b>Pcs x Box</b>	12
	<b>EAN</b>	8054633839959	<b>Box x Lyr</b>	28
	<b>Volume</b>	150 ml	<b>Box x Plt</b>	168



View the data sheet on your smartphone.





**SANITEC**  
Professional cleaning solutions



# Stone and metal surfaces

# Petranova

**Sanitec Petranova is the professional cleaning line dedicated to** the conservation cleaning and protection **of building and cladding materials**, natural and artificial stone and metal surfaces.

- **Conservative cleaning** of facades of public and private buildings
- **Cleaning of artefacts** of historical, artistic and monumental interest
- **Cleaning of natural and artificial stone surfaces**, fair-faced, high and low porosity stone surfaces such as travertine, tuff, sandstone, granite, porphyry, basalt, marble, Lecce stone, Noto stone, Serena stone, Sperone stone, Peperino stone, Trani stone, Luserna stone, terracotta, clinker, stoneware, cement and concrete mixes
- **Civil and industrial floor cleaning**
- **Graffiti and paint removal**
- **Elimination of saltpetre efflorescence**
- **End-of-site cleaning**
- **Metal and light alloy cleaning**
- **Protection of stone and metal surfaces**, preventing the absorption of water and pollutants



## Cleaning of artefacts of historical and artistic value

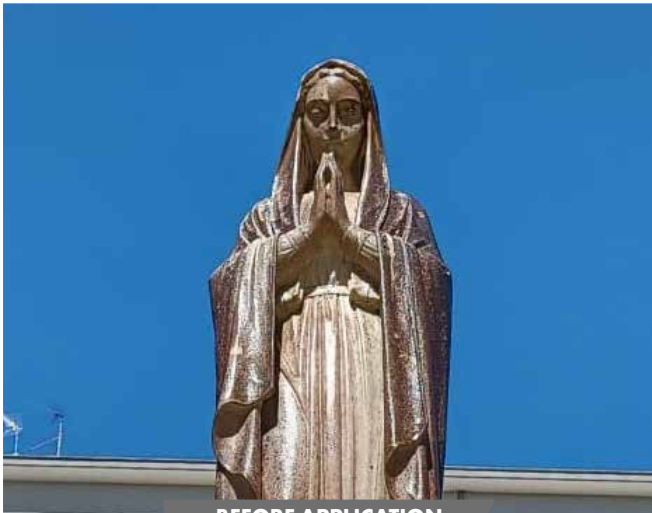

BEFORE APPLICATION

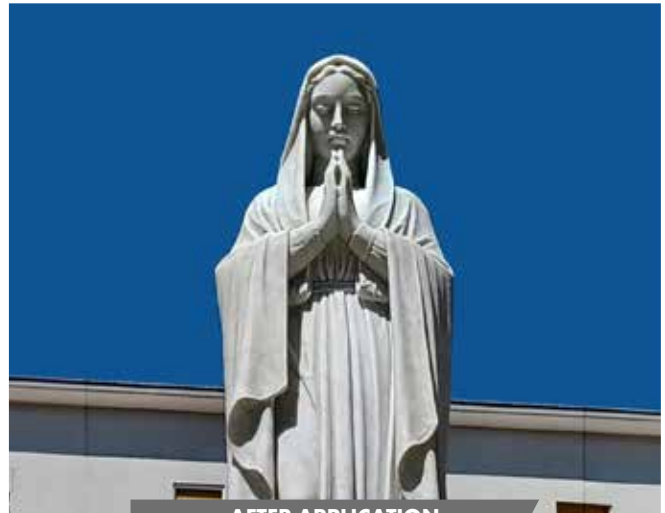

AFTER APPLICATION

## Interventions on facades of public and private buildings



BEFORE APPLICATION



AFTER APPLICATION

## Graffiti removal



BEFORE APPLICATION



AFTER APPLICATION

# BEFORE AFTER

APPLICATION APPLICATION



# PETRA 24<sup>©</sup>

## patented formula



**The product removes the most stubborn dirt, even centuries old, without attacking the treated surface, restoring it to its original splendour**

**Petra24<sup>®</sup>** is an industrially patented product **designed for effective and targeted conservation cleaning** on all high and low porosity stone surfaces. Specifically for the treatment of civil buildings, it is particularly suitable for cleaning artefacts of historical, artistic and monumental interest.

- **Removes the most difficult dirt** respecting all surfaces, even the most delicate ones
- **Removes patinas, black crusts, sulfation stains, moulds, algae and lichens**
- **It is effective against the blackening** of facades by smog and hydrocarbons
- **Ready to use** and easy to apply
- **Leaves no streaks** or surface films. **It is solvent-free**
- **It has no abrasive or oxidising/whitening properties**
- **Does not alter the chemical-physical characteristics** of treated surfaces
- **Safe** for humans and environment
- Gel formula **to adhere to vertical surfaces**

## PETRA 24<sup>®</sup>

Patented product



Gel cleaner for the conservative cleaning of all natural and artificial exposed stone surfaces, of high and low porosity

- Restores stone to its original splendour
- Removes the most stubborn dirt, even centuries old
- It removes patinas, sulfation stains (black crusts) and surface deposits of all kinds
- It is effective against smog and hydrocarbon dirt
- Respects the nature of the treated substrate

**Uses:** Public and private buildings, artefacts of historical, artistic and monumental interest. It is suitable for cleaning natural stone surfaces such as: travertine, tuff, marble, granite, slate, sandstone, porphyry, Serena stone, Lecce stone, Noto stone. And for cleaning artificial stone surfaces: exposed bricks, terracotta, clinker, stoneware, concrete, cement agglomerates

**Directions:** Apply the product to the surface to be cleaned, preferably dry. Using a brush or spatula, spread the product evenly, making sure to create a thickness of at least 2 mm. After application, cover the product with cling film. Wait 12 to 24 hours. Next, remove the film and proceed to wash using a low-pressure washer.

pH 8.5 - 9.5	NO HAZARD PICTOGRAMS	READY TO USE
-----------------	-------------------------	-----------------

15 L	Code	<b>7001</b>	Pcs x Box	1
	EAN	8050999570376	Box x Lyr	11
	Volume	15 L / 17,4 kg	Box x Plt	33



View the data sheet on your smartphone.

## POWER XP

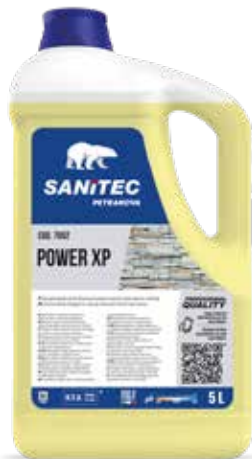

Highly effective alkaline cleaner for deep cleaning of natural and artificial stone surfaces

- Restores the artifact to its original state
- Removes organic and industrial dirt
- Effectively removes greasy dirt, patinas, crusts, sulphation stains and surface deposits of all kinds

**Uses:** Exposed bricks, terracotta, clinker, stoneware, cement and cement agglomerates, natural stone surfaces – such as travertine, granite, porphyry, basalt, marble, sandstone

**Directions:** Apply the product, as is, directly to the surface to be cleaned using a brush or a spray dispenser. Leave the product on for a few minutes: the time may vary depending on the type of surface and the type of dirt. If possible, rub with a brush and/or brushes with bristles suitable for the surface being treated. Subsequently rinse the surface with a low-pressure washer or manually with a brush and/or sorghum brush previously dampened with water. It works in minutes. It does not leave unpleasant odours during use.

pH 13 - 14	READY TO USE
---------------	-----------------



Code	<b>7002</b>	Pcs x Box	2
EAN	8050999570383	Box x Lyr	18
Volume	5 L / 6,3 kg	Box x Plt	72



View the data sheet on your smartphone.

## METAL BRO



Specific cleaner and deoxidiser for hard metal and light alloy surfaces

- Restores treated surfaces to their original splendour
- Cleans, deoxidizes and removes rust from all metal surfaces
- Removes limescale and oxidation
- Restores the original colour to surfaces such as copper (eliminates copper pesticide), brass and bronze
- Guarantees a long-lasting result. Respects the treated surfaces.
- Respects the treated surfaces

**Uses:** All metal surfaces such as bronze, copper, brass, steel and more.

**Directions:** Apply the product, as is, directly onto the surface to be cleaned using a brush, sponge or spray nozzle. Rub the surface clockwise and counterclockwise to loosen any dirt, using a cloth and/or sponge. Wait a few minutes - the time may vary depending on the type of dirt and surface - and rinse the surface. Easy to use. Non scratching.



Code	<b>7003</b>	Pcs x Box	2
EAN	8050999570413	Box x Lyr	18
Volume	5 L / 5,2 kg	Box x Plt	72



View the data sheet on your smartphone.

## GRAFFITI RM



Specific cleaning solvent for removing graffiti, inks and paints

- Effectively removes inks and paints from all natural and artificial, high and low porosity stone materials
- Safe product: non-flammable and not classified as dangerous for humans and the environment (easily biodegradable)
- Low VOC product: leaves no odours and does not release dangerous fumes

**Uses:** High and low porosity natural and artificial stone surfaces, unpainted metal surfaces

**Directions:** Apply the product, as is, on the dry surface with the help of a brush, sponge and/or spray nozzle. Leave the product on for a few minutes (about 15 minutes). Rub the surface to be cleaned vigorously using a brush, sponge or suitable bristle brushes, previously dampened with water. Rinse the surface with a cloth soaked in water, or with a low-pressure washer. Easy to use, and ready for use. It is not a flammable product, nor is it classified as dangerous to humans or the environment. Easily biodegradable. Low VOC product. It does not release dangerous fumes during its use, nor unpleasant odours. It can be used safely even indoors.



Code	<b>7004</b>	Pcs x Box	2
EAN	8050999570420	Box x Lyr	18
Volume	5 L / 5,5 kg	Box x Plt	72



View the data sheet on your smartphone.

## ACID SP

Descaling detergent made with hydrochloric acid for heavy soiling



- Quickly removes inorganic encrustations such as: limescale deposits, efflorescence from saltpetre, cement, plaster, rust
- Excellent for thoroughly cleaning newly laid floors
- Ideal for outdoor floors

**Uses:** All acid-resistant materials, terracotta surfaces, clinker, porcelain stoneware, glass mosaic, and all acid-resistant stones. Ideal for deep cleaning of newly laid floors

**Directions:** Dilute the product according to the recommended doses. Apply the product to the surface to be cleaned with a brush, sponge or spray. Leave the product on for a few minutes. Proceed to the rinsing phase using a pressure washer or manually with brushes wet with water.

**Dosage:** For deep cleaning of construction sites and removal of heavy dirt: dilute 200 - 250 ml/L (in a 1:3 - 1:4 ratio) of product with water. To remove saltpetre efflorescence and clean glass-ceramic coatings: dilute 110 - 150 ml/L (in a ratio of 1:6 - 1:8) of product with water.

**pH**  
0 - 1



Code	<b>7007</b>	Pcs x Box	2
EAN	8050999570505	Box x Lyr	18
Volume	5 L / 5,5 kg	Box x Pli	72



View the data sheet on your smartphone.

## AQUA

Water-based protective additive for hydrophobisation of all building materials



- The protective layer ensures effective protection against heavy rain and the accumulation of pollutants that are aggressive to surfaces
- Reduces water absorption
- Reduces the proliferation of mould or algae typical of stone products

**Uses:** Ideal for exposed natural and artificial stone surfaces. For surfaces such as concrete, terracotta and all medium-high porosity materials

**Directions:** Apply the product on dry surfaces without any surface dust. In the presence of highly absorbent surfaces, it is advisable to carry out two or more applications. It can be applied by brush, roller and spray. Dry any residue with a clean cloth.

**pH**  
12 - 13

**READY TO USE**



Code	<b>7005</b>	Pcs x Box	2
EAN	8050999570437	Box x Lyr	18
Volume	5 L / 5,1 kg	Box x Plt	72



View the data sheet on your smartphone.

## AQUA PLUS

Water-based protective additive designed for water-repellency of all building materials, even those with low porosity



- Guarantees effective protection against driving rain and pollutants.
- Reduces water absorption

**Uses:** Ideal for exposed natural and artificial stone surfaces. For surfaces such as concrete, terracotta and all medium-high porosity materials

**Directions:** Apply the product on dry surfaces without any surface dust. In the presence of highly absorbent surfaces, it is advisable to carry out two or more applications. It can be applied by brush, roller and spray.

**pH**  
4 - 5

**NO HAZARD PICTOGRAMS**

**READY TO USE**



Code	<b>7008</b>	Pcs x Box	2
EAN	8050999570857	Box x Lyr	18
Volume	5 L / 5 kg	Box x Plt	72



View the data sheet on your smartphone.

## HYDRO S



Water-based protective additive designed for water-repellency of all building materials, even those with low porosity

- Slows down the degrading action of pollutants on surfaces
- Ensures long-lasting protection
- Reduces water absorption

**Uses:** Ideal for low and high porosity surfaces. Natural and artificial stone facings, such as travertine, porphyry, Trani stone, Serena stone, granite, basalt, Luserna stone, slate, sandstone, terracotta, klinker, concrete, cement agglomerates, marble

**Directions:** Apply the product to a clean, dry surface using a brush or low-pressure lance. Dry any residues with a clean cloth.



Code	<b>7006</b>	Pcs x Box	2
EAN	8050999570444	Box x Lyr	18
Volume	5 L / 4 kg	Box x Plt	72



View the data sheet on your smartphone.

## Table of surface-cleaner compatibility

	PETRA 24	POWER XP	METAL BRO	GRAFFITI RM	ACID SP	AQUA	AQUA PLUS	HYDRO S
Travertine	●	●		●		●	●	●
Porphyry	●	●		●	●	●	●	●
Tuff	●	●		●		●	●	●
Trani stone	●	●		●		●	●	●
Granite	●	●		●	●	●	●	●
Basalt	●	●		●	●	●	●	●
Luserna stone	●	●		●		●	●	●
Quartzite	●	●		●	●	●	●	●
Slate	●	●		●		●	●	●
Sandstone	●	●		●		●	●	●
Marble	●	●		●		●	●	●
Fair-faced bricks	●	●		●	●	●	●	●
Terracotta	●	●		●	●	●	●	●
Klinker	●	●		●	●	●	●	●
Cement	●	●		●	●	●	●	●
Cementitious aggregates	●	●		●	●	●	●	●
Porcelain Stoneware		●		●	●	●	●	●
Ceramics				●	●	●	●	●
Bronze			●	●				
Copper			●	●				
Brass			●	●				
Steel			●	●				





# Industry

# DETERGENTS

## EMULSI CHLOR



Alkaline foaming active chlorine detergent for all surfaces

- Effectively removes all organic residues and blood
- Foaming formula that adheres perfectly even to vertical walls

**Directions:** Spread the solution on the surfaces and equipment to be treated, leave on for the time necessary to dissolve the dirt, rinse with plenty of water. The use of low or medium pressure foaming equipment is recommended to improve the product's action.

**Dosage:** 10-20 ml/L (1-2%) depending on the degree of dirt.

pH  
13 - 14



15 L	Code	1859	Pcs x Box	1
	EAN	8054633830437	Box x Lyr	13
	Volume	15 L / 17.3 kg	Box x Plt	52



View the data sheet on your smartphone.

## EMULSI FOAM



Alkaline foaming degreasing detergent for all surfaces

- Effectively removes all heavy soiling including grease, starch and protein
- Foaming formula that adheres perfectly even to vertical walls

**Directions:** Spread the solution on the surfaces and equipment to be treated, leave on for the time necessary to dissolve the dirt, rinse with plenty of water. The use of low or medium pressure foaming equipment is recommended to improve the product's action.

**Dosage:** 10-30 ml/L (1-3%) depending on the degree of dirt.

pH  
13 - 14



15 L	Code	1852	Pcs x Box	1
	EAN	8054633830376	Box x Lyr	13
	Volume	15 L / 17.3 kg	Box x Plt	52



View the data sheet on your smartphone.

## EMULSI CIP



Non-foaming alkaline detergent suitable for CIP systems

- Particularly effective in removing all heavy dirt including grease starch and protein
- Easily rinsed, it is ideal for use with automated CIP cleaning systems and immersion, which dosed with low pressure systems

**Directions:** Spread the solution on the surfaces and equipment to be treated with a sponge brush or low-pressure foamer, leave on for the time necessary to dissolve the dirt, rinse with plenty of water. USE IN CIP: Place the product through dosing systems inside the recirculation system and proceed with cleaning. Ideal for meat, fish, vegetable and agri-food processing industries in general.

**Dosage:** 10-20 ml/L (1-2%) depending on the degree of dirt.

pH  
13 - 14



15 L	Code	2142	Pcs x Box	1
	EAN	8054633830307	Box x Lyr	13
	Volume	15 L / 18.5 kg	Box x Plt	52



View the data sheet on your smartphone.

## EMULSI HYPOCHLOR



Active chlorine non-foaming alkaline detergent

- Effectively removes all organic residues and blood
- Easily rinseable, it is ideal for use with automated CIP cleaning systems. and by immersion and also dosed with low pressure systems

**Directions:** Spread the solution on the surfaces and equipment to be treated with a sponge brush or low-pressure foamer, leave on for the time necessary to dissolve the dirt, rinse with plenty of water. USE IN CIP: Place the product through dosing systems inside the recirculation system and proceed with cleaning.

**Dosage:** 10-20 ml/L (1-2%) depending on the degree of dirt.

pH  
13 - 14



15 L	Code	1863	Pcs x Box	1
	EAN	8054633830444	Box x Lyr	13
	Volume	15 L / 18.8 kg	Box x Plt	52



View the data sheet on your smartphone.

## EMULSI KAL



Phosphoric acid-based descaling foam detergent for all surfaces

- Particularly suitable for the removal of limescale deposits due to water hardness, and other mineral deposits
- Foaming formula that adheres perfectly even to vertical walls

**Directions:** Spread the solution on the surfaces and equipment to be treated, leave on for the time necessary to dissolve the dirt, rinse with plenty of water. The use of low or medium pressure foaming equipment is recommended to improve the product's activity and to avoid aerosols.

**Dosage:** 3-10 ml/L (0.3-1%) depending on the degree of dirt.

pH  
0.7 - 1.7



15 L	Code	1856	Pcs x Box	1
	EAN	8054633830369	Box x Lyr	13
	Volume	15 L / 18.5 kg	Box x Plt	52



View the data sheet on your smartphone.

## EMULSI ACID



Organic and peracetic acid non-foaming acid detergent

- Particularly effective in removing all organic residues and blood
- Easily rinsed, it is ideal for use with automated CIP cleaning systems and immersion, which dosed with low pressure systems

**Directions:** Spread the solution on the surfaces and equipment to be treated with a sponge brush or low-pressure foamer, leave on for the time necessary to dissolve the dirt, rinse with plenty of water. USE IN CIP: Place the product through dosing systems inside the recirculation system and proceed with cleaning.

**Dosage:** 10-30 ml/L (1-3%) depending on the degree of dirt.

pH  
0.5 - 1.5



15 L	Code	1858	Pcs x Box	1
	EAN	8054633830420	Box x Lyr	13
	Volume	15 L / 15.8 kg	Box x Plt	52



View the data sheet on your smartphone.

# HAND DETERGENTS

## INDUSTRIAL SOAP | Citrus



Specific liquid soap for stubborn dirt

- Excellent emulsifying power of mechanical oils and greases thanks to a formula with a high concentration of oleic acid
- Ideal for the industrial, mechanical and steel sectors

**Directions:** Apply the product to moistened hands. Rub until a soft lather is obtained, taking care to rub the spaces between the fingers and also the wrists for about 30 seconds. Rinse with water. Dry thoroughly.

**Dosage:** Ready to use.



Code	1040	Pcs x Box	6
EAN	8032680397547	Box x Lyr	15
Volume	1000 ml	Box x Pli	90



View the data sheet on your smartphone.

## INDUSTRIAL SOAP | Lemon



Specific liquid soap for stubborn dirt with scrub microgranules

- Contains biodegradable natural cellulose microgranules for more effective removal of dirt
- Excellent emulsifying power of mechanical oils and greases
- Ideal for the industrial, mechanical and steel sectors

**Directions:** Apply the product to moistened hands. Rub until a soft lather is obtained, taking care to rub the spaces between the fingers and also the wrists for about 30 seconds. Rinse with water. Dry thoroughly.

**Dosage:** Ready to use.

Each box contains 1 pc. **Dispenser for 5L can** code **I2388** description below



Code	1045	Pcs x Box	2
EAN	8032680391262	Box x Lyr	18
Volume	5 L / 4.7 kg	Box x Pli	72



View the data sheet on your smartphone.

## 5L CAN DISPENSER



Dispensing pump

- Precise, fast and safe
- Ensures hygiene and practicality

Manual dispenser	Code	I2388
	EAN	-
	Volume	-







# Swimming pool

# SWIMMING POOL WATER TREATMENT

## DICHLOR 56%



Chlorine-based granular additive for water treatment

- Continuous protection over time thanks to the presence of a stabilizer, which keeps chlorine active for longer, reducing consumption and replenishment
- Stabilizes and protects chlorine from solar degradation, prolonging its effectiveness, up to 80% thanks to the formula based on highly stabilized isocyanuric acid.
- pH always under control thanks to the slightly acidic reaction dissolution, which helps keep water in its optimal balance

**Directions:** Manual dosing: the product can be dosed inside the skimmers. It can be dosed in the compensation tank or directly in the pool, making sure there are no swimmers present. For the optimal dose, consider 1 g per m<sup>3</sup> of water raises the chlorine value by 0.55 mg/L. Automatic dosing: prepare a chlorinating solution with 10-30 g/L (1-3%) in water, adjust the dosers that deliver the chlorinating solution directly into the pool so as to obtain a chlorine content in the pool that complies with current regulations.

**Dosage:** 1-2 g every m<sup>3</sup> of water per day. For best product performance, keep the water pH at 7.2. Consumption may vary depending on temperature, light intensity, attendance of the system and weather conditions.

pH  
6 - 7



Code	<b>2613</b>	Pcs x Box	1
EAN	8032680393754	Box x Lyr	24
Volume	5 kg	Box x Plt	144



View the data sheet on your smartphone.



Code	<b>2607</b>	Pcs x Box	1
EAN	8032680390463	Box x Lyr	12
Volume	25 kg	Box x Plt	24



View the data sheet on your smartphone.

## LIQUID CHLOR



Liquid chlorine 14-15% for swimming pool water treatment

- Effective in superchlorination treatments
- Can also be used without pre-dilution
- Contains raw materials with high oxidizing power

**Directions and dosage:** Automatic dosage: dose with a special dosing pump into the pool inlet water until 0.7-1.5 ppm of free active chlorine is obtained in the pool. Manual dosage: dose approximately 30-50 ml of product for each m<sup>3</sup> of water in the skimmers, or in the compensation tank or directly in the pool if there are no swimmers. For best product performance, keep the water pH at 7.2.

pH  
12.5 - 13.5



Code	<b>2082</b>	Pcs x Box	1
EAN	8054633833599	Box x Lyr	13
Volume	15 L / 18.8 kg	Box x Plt	52



View the data sheet on your smartphone.

## ANTI CHLOR



Liquid chlorine remover

- Quickly and effectively restores/reduces chlorine levels to normal
- Immediate savings because it avoids changing the water to reduce chlorine
- Safe for water and swimmers

**Directions:** Automatic dosing: dose with a special dosing pump into the pool inlet water. Manual dosing: dose the product into the compensation tank or directly into the pool if there are no swimmers.

**Dosage:** 4-5 ml of product per m<sup>3</sup> of water reduces the chlorine value by about 1 ppm. CAUTION: do not pour product into skimmers. Avoid contact with iron, aluminium and brass.

pH  
5 - 6



Code	<b>2618</b>	Pcs x Box	2
EAN	8054633835531	Box x Lyr	18
Volume	5 L / 6 kg	Box x Plt	72



View the data sheet on your smartphone.

## ALGHICIDA



Product for the treatment of algae in swimming pool water

- Total protection thanks to a broad-spectrum formula, helps keep water in perfect condition
- Suitable for preventive treatment of the formation and elimination of algae already present in the pool

**Directions and dosage:** Initial treatment: with the pool empty, apply the product as is directly to the walls and bottom. Once the pool is full, pour the product directly into the pool. Dosage 30-50 ml per m<sup>3</sup> of water. Maintenance treatment: pour the product into the pool, 20-30 ml per m<sup>3</sup> of water every week. Shock treatment: pour the product into the pool, 50-70 ml per m<sup>3</sup> of water in addition to a superchlorination treatment bringing the free chlorine to 5 ppm. Treatments must be carried out in the absence of bathers in the pool.

**pH**  
10 - 11



Code	<b>2609</b>	Pcs x Box	2
EAN	8032680393716	Box x Lyr	18
Volume	5 L / 5 kg	Box x Plt	72



View the data sheet on your smartphone.

## FLOCCULANT



Product for flocculation and clarification of swimming pool water

- Instantly clearer water thanks to the effective flocculation that aggregates and removes the finest particles responsible for turbidity
- Less encrustations and less correctors because regular use reduces deposits and consumption of pH-regulating products
- Targeted action on difficult waters because it is ideal against iron, manganese and ammonia, main causes of clouding

**Directions:** In skimmer pools, pour the product into the skimmers. In infinity pools, pour the product into the compensation tank near the water intake. CAUTION: do not use the product on filtration systems that use fossil meal such as diatomaceous earth.

**Dosage:** 0.6-2.5 ml per m<sup>3</sup> of water

**pH**  
1.5 - 2.5



Code	<b>2616</b>	Pcs x Box	1
EAN	8054633830383	Box x Lyr	13
Volume	15 L / 20.4 kg	Box x Plt	52



View the data sheet on your smartphone.

## pH+



Soda-based pH booster

- Maintains the correct pH at the optimal value of 7.2 - 7.4
- It has an adjuvant effect in the precipitation treatments of metals such as iron and manganese

**Directions:** Automatic dosing: dose with a special dosing pump into the pool inlet water. Manual dosing: dose the product into the compensation tank or directly into the pool if there are no swimmers.

**Dosage:** 6-7 ml of product per m<sup>3</sup> of water raises the pH value by 0.1. CAUTION: do not pour product into skimmers.

**pH**  
13 - 14



Code	<b>2615</b>	Pcs x Box	1
EAN	8054633830239	Box x Lyr	13
Volume	15 L / 19.8 kg	Box x Plt	52



View the data sheet on your smartphone.

# SWIMMING POOL WATER TREATMENT

## pH-



### Sulphuric Acid pH Reducer

- Maintains the correct pH at the optimal value of 7.2 - 7.4
- Prevents the formation of scale

**Directions:** Automatic dosing: dose with a special dosing pump into the pool inlet water. Manual dosing: dose the product into the compensation tank or directly into the pool if there are no swimmers.

**Dosage:** 6-7 ml of product per m<sup>3</sup> of water lowers the pH value by 0.1. CAUTION: do not pour product into skimmers.

pH  
0 - 1

15 L	Code	2617	Pcs x Box	1
	EAN	8054633830390	Box x Lyr	13
	Volume	15 L / 18.9 kg	Box x Plt	52



View the data sheet on your smartphone.

## RUDERAL | Balsamic



Universal descaler made with hydrochloric acid for hard surfaces, for heavy fouling

- Quickly and effectively dissolves treated encrustations
- Suitable for the removal of stubborn limescale deposits and rust
- Ideal for extraordinary cleaning operations of floors and walls inside baths, swimming pools and spa areas

**Directions:** Dilute the product in water according to the instructions, spread it on the surfaces to be treated and leave it on for a few minutes. Scrub to remove stubborn build-up, then rinse with plenty of water.

**Dosage:** 20-40 ml/L (2-4 caps every 5 litres) depending on the degree of soiling.

pH  
0 - 1



5 L	Code	1976	Pcs x Box	2
	EAN	8032680392757	Box x Lyr	18
	Volume	5 L / 5.3 kg	Box x Plt	72



View the data sheet on your smartphone.







---

# Ecolabel



# Sanitec Ecolabel Range

## Excellent cleaning performance with reduced environmental impact

Within the Sanitec portfolio, **EU Ecolabel-certified products** stand out, designed to deliver high cleaning standards with increased attention to environmental impact.

Sanitec **EU Ecolabel-certified** formulations represent a responsible choice for professional cleaning: products that combine **excellent cleaning performance with strict environmental criteria**.

Choosing **EU Ecolabel-certified** products means relying on solutions that help **reduce environmental impact throughout the entire product life cycle**, from raw material selection and formulation to use and disposal. At the same time, they ensure **effectiveness, safety and quality**, meeting the needs of cleaning professionals and the expectations of facilities that are increasingly focused on sustainability.

The Sanitec Ecolabel range therefore enables a **more sustainable, efficient and responsible** approach to cleaning, without compromising on performance.

## STOVIL GREEN POWER



Alkaline liquid detergent concentrate **Ecolabel-certified**, for mechanical dishwashing, for all water hardnesses

- EU Ecolabel-certified product with low environmental impact
- Effectively removes encrusted grease and food residues
- Prevents limescale build-up on dishes
- Excellent rinsability

**Directions:** To be used with Sanitec automatic dispensers, or in combination with dosing systems integrated into the machine when present.

**Dosage:** Adjust the dispenser to 1-3.5 ml/L depending on the degree of dirt and water hardness. The recommended dosage refers to the use of the product under optimal conditions. Consult Sanitec Service technical support for dosage adjustment.



**pH**  
13 - 14



	Code	<b>4017</b>	Pcs x Box	2
	EAN	8054633834619	Box x Lyr	18
	Volume	5 L / 6.3 kg	Box x Plt	72



	Code	<b>4018</b>	Pcs x Box	1
	EAN	8054633834626	Box x Lyr	13
	Volume	15 L / 18.9 kg	Box x Plt	52



## BRILL GREEN POWER



Rinse aid, **Ecolabel-certified**, for mechanical dishwashing, for all water hardnesses

- EU Ecolabel-certified product with low environmental impact
- Speeds up the drying of dishes, also effective on plastic
- Eliminates bad odours
- Reduces limescale build-up on dishes

**Directions:** To be used with Sanitec automatic dispensers, or in combination with dosing systems integrated into the machine when present.

**Dosage:** Adjust the dispenser to 1-2 ml/L depending on the degree of dirt and water hardness. The recommended dosage refers to the use of the product under optimal conditions. Consult Sanitec Service technical support for dosage adjustment.



**pH**  
2,1 - 3,1



	Code	<b>4019</b>	Pcs x Box	2
	EAN	8054633834633	Box x Lyr	18
	Volume	5 L / 5.4 kg	Box x Plt	72



	Code	<b>4020</b>	Pcs x Box	1
	EAN	8054633834640	Box x Lyr	13
	Volume	15 L / 16.2 kg	Box x Plt	52



## NEOPOL GREEN POWER | Unscented



Concentrated liquid detergent, **Ecolabel-certified**, for manual dishwashing

- EU Ecolabel-certified product with low environmental impact
- Effectively removes grease and organic dirt
- Eliminates odours from dishes
- Leaves dishes sparkling without streaks
- Effective cleaning with compact foam and immediate rinsing
- Product with neutral pH, dermatologically tested

**Directions:** Pour the dose of product into warm water, leave the dishes to soak for the time necessary to soften the dirt, when necessary use a sponge/brush directly on the stubborn dirt, then rinse and leave to dry.

**Dosage:** 1-1.2 ml/L per litre of water, depending on the degree of dirt (1 push = 4 ml)



**pH**  
6,5 - 7,5



	Code	<b>3106</b>	Pcs x Box	6
	EAN	8054633838600	Box x Lyr	15
	Volume	1000 ml	Box x Plt	90



	Code	<b>3104</b>	Pcs x Box	2
	EAN	8032680393662	Box x Lyr	18
	Volume	5 L / 5.2 kg	Box x Plt	72



## DEKAL GREEN POWER



**Ecolabel-certified** acid descaler for removing limescale from tools, machines and equipment

- EU Ecolabel-certified product with low environmental impact
- When used regularly, it helps maintain the performance of the equipment and increases longevity
- Excellent for recirculating washing also due to its low foaming
- Safe on metals and all types of machinery

**Directions:** Small surfaces/stubborn dirt: apply the product as is directly to the surface to be cleaned, leave to act for a few minutes and then rub with a clean, damp cloth. Rinse thoroughly with water. Soaking: dilute the product at a concentration of 30 ml per litre of hot water (3 caps every 5 litres) depending on the extent of the encrustation. Leave to soak until the limescale deposit has dissolved. If necessary, use a sponge or brush to remove more stubborn limescale deposits. Rinse thoroughly with water. Spray Method: spray on the surface or equipment to be treated. Leave on and rub. Rinse thoroughly with water. Dishwasher/Washing Machine: make sure the machine is completely empty. Pour the product directly into the tray, 30 ml for every litre of water (3 caps for every 5 litres). Run an empty wash cycle at 50-60°C.



Code	<b>3113</b>	Pcs x Box	2
EAN	8054633838730	Box x Lyr	18
Volume	5 L / 5.5 kg	Box x Plt	72



View the data sheet on your smartphone.

## ULTRA DEGREASER GREEN POWER



**Ecolabel-certified** universal degreaser for stubborn dirt

- EU Ecolabel-certified product with low environmental impact
- Effectively removes dirt, grease, oil and charred residues
- Ideal for the catering sector, industry, garages, offices, warehouses, hospitals

**Directions:** Dispense the product directly onto the surface to be cleaned, allow it to act for a few minutes and then wipe with a clean, damp cloth. Rinse thoroughly with water.

**Dosage:** Ready to use.



Code	<b>3101</b>	Pcs x Box	6
EAN	8032680393693	Box x Lyr	21
Volume	750 ml	Box x Plt	105



View the data sheet on your smartphone.

## SURFACE GREEN POWER | Floral



Universal detergent, **Ecolabel-certified**, for floors and hard surfaces

- EU Ecolabel-certified product with low environmental impact
- Excellent degreasing power, removes all types of dirt
- Does not require rinsing and leaves no streaks
- Controlled foam can be used with mop method or with scrubbers

**Directions:** Ideal for all types of water-resistant washable floors. **Small surfaces/stubborn dirt:** Apply the product as is directly to the surface to be cleaned, leave on for a few minutes and then rub with a clean, damp cloth. Rinse with water. **Large surfaces/ordinary cleaning:** Dilute the product in water, apply the product to the surface to be washed with a mop or cloth. No rinsing required.

**Dosage:** 10-30 ml/L (Code 3109-S: 2-6 caps every 5 litres, Code 3105: 1-3 caps every 5 litres) depending on the degree of dirt.



	Code	<b>3109-S</b>	Pcs x Box	6
	EAN	8054633837085	Box x Lyr	21
	Volume	1000 ml	Box x Plt	105



	Code	<b>3105</b>	Pcs x Box	2
	EAN	8032680393679	Box x Lyr	18
	Volume	5 L / 5.1 kg	Box x Plt	72



## IGIENIKAL GREEN POWER | Floral



**Ecolabel-certified** citric acid-based descaling detergent for bathrooms and bathroom fittings

- EU Ecolabel-certified product with low environmental impact
- Quickly dissolves greasy residues, soap residues and limescale residues from sinks, shower cubicles, taps, bathroom fittings, tiles, etc.
- Leaves surfaces shiny

**Directions:** Dispense the product directly onto the surface to be cleaned, allow it to act for a few minutes and then wipe with a clean, damp cloth. Rinse thoroughly with water.

**Dosage:** Ready to use.



	Code	<b>3103</b>	Pcs x Box	6
	EAN	8032680393686	Box x Lyr	21
	Volume	750 ml	Box x Plt	105



## WC GEL GREEN POWER | Pine



Descaling detergent with **Ecolabel certificate** made with citric acid and lactic acid for toilets and urinals

- EU Ecolabel-certified product with low environmental impact
- Effective in removing limescale and organic dirt
- It adheres perfectly to vertical surfaces thanks to the gel formula
- Quick and easy to apply thanks to the bottle with multi-jet action cap for a wide coverage of the surface to be cleaned

**Directions:** Run water into the toilet bowl/urinal. Apply the product around the bowl and on the water flow walls. Leave on for 15 minutes, scrub with a brush or abrasive cloth to remove more stubborn stains, then run water to rinse.

**Dosage:** Ready to use.



	Code	<b>1945</b>	Pcs x Box	8
	EAN	8050999570703	Box x Lyr	20
	Volume	700 ml	Box x Plt	100



## CRYSTAL GREEN POWER



**Ecolabel-certified** multi-purpose cleaner for glass, mirrors and dusting

- EU Ecolabel-certified product with low environmental impact
- Leaves surfaces clean and shiny without streaks
- Ideal for glass, mirrors and chrome plated surfaces

**Directions:** Dispense the product directly onto the surface to be cleaned and rub until completely dry.

**Dosage:** Ready to use.



Code	<b>3102</b>	Pcs x Box	6
EAN	8032680393655	Box x Lyr	21
Volume	750 ml	Box x Plt	105



View the data sheet on your smartphone.

## QUANTUM BASIC



Concentrated alkaline sequestrant detergent

- Quantum System **Ecolabel-certified**, environmentally friendly
- Effectively removes dirt by increasing the alkalinity of the wash bath
- Avoids the redeposition of removed dirt on fibres due to formula with anti-redeposition agents
- Prevents greying of fabrics
- Suitable for delicate, coloured clothes and microfibre mops and cloths

**Directions:** For use with L-Brain Connect automatic dosing systems only. It must be used during the pre-wash or wash phase. For optimum results, we recommend using Quantum system products. Do not use on wool and delicates.

**Dosage:** 0,5-4 ml/kg of dry laundry. The recommended dosage refers to the use of the product under optimal conditions. Consult Sanitec Service technical support for dosage adjustment.



Code	<b>2051HC</b>	Pcs x Box	2
EAN	8032680390098	Box x Lyr	18
Volume	5 L / 6.6 kg	Box x Plt	72



View the data sheet on your smartphone.



Code	<b>2077HC</b>	Pcs x Box	1
EAN	8054633835784	Box x Lyr	13
Volume	15 L / 19.8 kg	Box x Plt	52



View the data sheet on your smartphone.

## QUANTUM SURF



Concentrated stain removal detergent with enzymes and optical brighteners, for white and coloured fabrics

- Quantum System **Ecolabel-certified**, environmentally friendly
- Effectively removes greasy and enzymatic soiling. Provides excellent whiteness. Prevents greying of fabrics
- Formulated with **Proactive System** technology that protects fibres from the redeposition of dirt

**Directions:** For use with L-Brain Connect automatic dosing systems only. It must be used during the pre-wash or wash phase. For optimum results, we recommend using the Quantum system products

**Dosage:** 1-3 ml/kg of dry laundry. The recommended dosage refers to the use of the product under optimal conditions. Consult Sanitec Service technical support for dosage adjustment.



Code	<b>2052HC</b>	Pcs x Box	2
EAN	8032680390111	Box x Lyr	18
Volume	5 L / 5.2 kg	Box x Plt	72



View the data sheet on your smartphone.



Code	<b>2076HC</b>	Pcs x Box	1
EAN	8054633835791	Box x Lyr	13
Volume	15 L / 15.6 kg	Box x Plt	52



View the data sheet on your smartphone.

## QUANTUM OXYGEN



Concentrated active oxygen bleach for fabrics

- Quantum System **Ecolabel-certified**, environmentally friendly
- Effectively cleans fabrics, including colours.
- Can be used on all types of fabric
- Can also be used at temperatures above 60°C

**Directions:** For use with L-Brain Connect automatic dosing systems only. It must be used during the pre-wash or wash phase. Optimised for use with Quantum system products. For all white and coloured fabrics resistant to active oxygen bleaching.

**Dosage:** 2-10 ml/kg of dry laundry. The recommended dosage refers to the use of the product under optimal conditions. Consult Sanitec Service technical support for dosage adjustment.



	Code	<b>2050HC</b>	Pcs x Box	2
	EAN	8032680390173	Box x Lyr	18
	Volume	5 L / 5.7 kg	Box x Plt	72



	Code	<b>2049HC</b>	Pcs x Box	1
	EAN	8054633835777	Box x Lyr	13
	Volume	15 L / 17 kg	Box x Plt	52



## QUANTUM SOFT ECO | Floral



Scented neutralising concentrated softener with odour-eliminating molecule

- Quantum System **Ecolabel-certified**, environmentally friendly
- Softer laundry thanks to a formulation that prevents the build-up of electrostatic charges on the fabric during drying and ironing
- Leaves a pleasant fragrance

**Directions:** Optimised for use with Quantum system products. For use with L-Brain Connect automatic dosing systems only. It must be used during the rinsing phase.

**Dosage:** 1-3 ml/kg of dry laundry. The recommended dosage refers to the use of the product under optimal conditions. Consult Sanitec Service technical support for dosage adjustment.



	Code	<b>2065HC</b>	Pcs x Box	2
	EAN	8054633839782	Box x Lyr	18
	Volume	5 L / 5 kg	Box x Plt	72



## WASHDET GREEN POWER | Floral



**Ecolabel-certified** enzymatic concentrated detergent for washing all types of fabrics

- Low environmental impact
- Effective on even the most stubborn stains
- Complete product with surfactants and enzymes

**Directions:** Pour the product in and proceed with normal washing.

**Dosage:** 3-6 ml per kg of dry linen depending on the degree of soiling and water hardness, 50 ml per 4.5 kg of dry linen



	Code	<b>3112</b>	Pcs x Box	2
	EAN	8054633837948	Box x Lyr	18
	Volume	5 L / 5.2 kg	Box x Plt	72



## LIQUID SOAP GREEN POWER | Floral



Ecolabel-certified scented liquid soap with ingredients of natural origin

- EU Ecolabel-certified product with low environmental impact
- Gently cleanses hands and body
- Dermatologically tested

**Directions:** Apply the product to moistened hands. Rub until a soft lather is obtained, taking care to rub the spaces between the fingers and also the wrists for about 30 seconds. Rinse with water. Dry thoroughly.

**Dosage:** Ready to use.



Code	<b>4015</b>	Pcs x Box	6
EAN	8054633831045	Box x Lyr	15
Volume	1000 ml	Box x Plt	90



View the data sheet on your smartphone.



Code	<b>4006</b>	Pcs x Box	2
EAN	8032680394393	Box x Lyr	18
Volume	5 L / 5.1 kg	Box x Plt	72



View the data sheet on your smartphone.

## MOUSSE SOAP GREEN POWER | Floral



Scented soap mousse for daily cleaning of hands and body, Ecolabel-certified, with ingredients of natural origin

- EU Ecolabel-certified product with low environmental impact
- Gently cleanses hands and body
- Dermatologically tested

**Directions:** Apply the product to moistened hands. Rub between the fingers and also the wrists for about 30 seconds. Rinse with water. Dry thoroughly.

**Dosage:** Ready to use.



Code	<b>4005</b>	Pcs x Box	6
EAN	8050999570208	Box x Lyr	20
Volume	600 ml	Box x Plt	120



View the data sheet on your smartphone.



Code	<b>1091</b>	Pcs x Box	2
EAN	8050999570192	Box x Lyr	18
Volume	5 L / 5.1 kg	Box x Plt	72



View the data sheet on your smartphone.

## MOUSSE SOAP GREEN POWER | Floral



Scented soap mousse for daily cleaning of hands and body, Ecolabel-certified, with ingredients of natural origin

- EU Ecolabel-certified product with low environmental impact
- Gently cleanses hands and body
- Dermatologically tested

**Directions:** Pour into the appropriate bottle. Then apply the product to moistened hands with the dispenser. Rub between the fingers and also the wrists for about 30 seconds. Rinse with water and dry.

**Dosage:** Ready to use.

Product compatible with manual dispenser code 265 or automatic code 266 on p. 125



Code	<b>1061</b>	Pcs x Box	6
EAN	8032680397387	Box x Lyr	14
Volume	800 ml	Box x Plt	84



View the data sheet on your smartphone.

## GREEN POWER KIT



A complete selection of **Ecolabel-certified** cleaning products, to satisfy every professional need

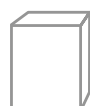

Code **1005-S**  
EAN IC 18050444498429



### MOUSSE SOAP

GREEN POWER

Code **4005**  
EAN 8050999570208  
Pack 1 pcs x 600 ml

Product details on page 123



### ULTRA DEGREASER

GREEN POWER

Code **3101**  
EAN 8032680393693  
Pack 1 pcs x 750 ml

Product details on page 74



### CRYSTAL

GREEN POWER

Code **3102**  
EAN 8032680393655  
Pack 1 pcs x 750 ml

Product details on page 74



### SURFACE

GREEN POWER

Code **3109-S**  
EAN 8054633837085  
Pack 1 pcs x 1000 ml

Product details on page 51



### IGIENIKAL

GREEN POWER

Code **3103**  
EAN 8032680393686  
Pack 1 pcs x 750 ml

Product details on page 66



### WCgel

GREEN POWER

Code **1945**  
EAN 8050999570703  
Pack 1 pcs x 700 ml

Product details on page 70





**SANITEC**  
Professional cleaning solutions

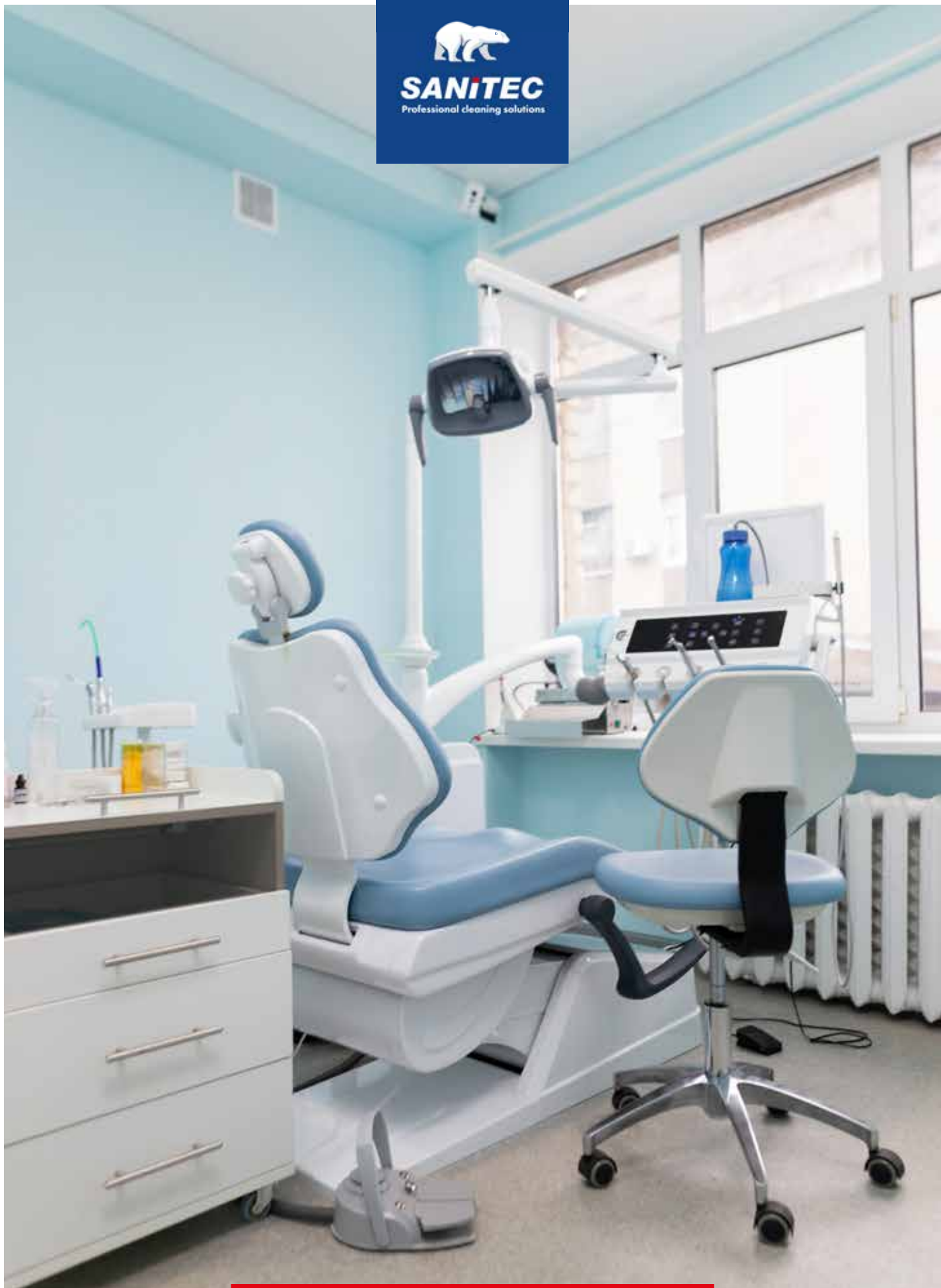

# Disinfectants

# Safety at your fingertips

Medical Surgical Device (in Italy: Presidio Medico Chirurgico (P.M.C.)) products are chemical solutions specially formulated to ensure the elimination of microorganisms such as bacteria, fungi and viruses from the environment. The P.M.C. offer Sanitec comprises a complete range of products designed to guarantee total safety in the ordinary and extraordinary disinfection process of all surfaces. Each product guarantees a specific level of disinfection and is designed to always ensure the most suitable solution for your needs.

- Guaranteed and safe sanitising process for guests
- Reducing the risk of contamination from environmental factors
- Compliance with ministerial requirements regarding sanitisation of treated areas
- Helps reduce the proliferation of bacteria, fungi and viruses
- Concentrated, ready-to-use solutions for surfaces and skin

## Tested action: virucidal, fungicidal and bactericidal

Tests carried out by internationally accredited laboratories guarantee its effectiveness

P.M.C. products from the Sanitec surface care line have successfully passed microbiological activity tests: EN 1276 "Bactericidal activity with interfering substances", EN 1650 "Fungicidal activity with interfering substances". EN 13697 'Bactericidal/fungicidal activity surface test', Multi activ, Bakterio and Sanimed also passed the activity tests against viruses EN 14476 'Virucidal activity suspension test' and EN 16777 'Virucidal activity surface test'.

P.M.C. products from the Sanitec line for skin care have successfully passed the microbiological activity tests: EN 13727 "Bactericidal activity in suspension", EN 13624 "Fungicidal activity in suspension", EN 14476 "Virucidal activity in suspension test", in addition Sani gel med passed the specific test EN 1500 "Hygienic hand washing by rubbing" and securgerm med the specific test EN 1499 "Hygienic hand washing".



## SANI ACTIVE | Unscented



Universal bactericidal and yeasticidal degreaser according to **Italian Ministry of Health**, Registration no. 20440.

- Eliminates 99.9% of bacteria and fungi
- Ideal in all cases where cleaning and disinfection are required in a single operation
- Disinfects and degreases all surfaces in the kitchen, bathroom, offices, and other public environments, cars and waste collection containers, even in the presence of stubborn dirt
- Also recommended for the agri-food and healthcare sectors, on food contact surfaces, and for those in contact with elderly people and children

**Directions:** For normal cleaning, spray directly to the surface to be treated and then dry with a cloth or paper. To disinfect, spray and leave on for at least 15 minutes, then dry with a cloth, paper or rinse.

**Dosage:** See the terms of use in the table.



Code	1804-S	Pcs x Box	6
EAN	8054633834602	Box x Lyr	21
Volume	750 ml	Box x Plt	105



View the data sheet on your smartphone.

### Active ingredient

N-(3-aminopropyl)-N-dodecylpropane-1,3-diamine 0.32 g/100 g



**Product code** 1804-S

**Active ingredient** N-(3-aminopropyl)-N-dodecylpropane-1,3-diamine 0.32 g/100 g

### Bactericidal efficacy

### Fungicidal efficacy

#### Regulation

UNI EN 1276:2009  
UNI EN 13697:2015

UNI EN 1650:2013  
UNI EN 13697:2015

#### Tested organisms

Pseudomonas aeruginosa  
Staphylococcus aureus  
Enterococcus hirae  
Escherichia coli

Candida albicans

#### Conditions of use

Concentration: Ready to use  
Contact time: 5 minutes  
Dirt conditions

Concentration: Ready to use  
Contact time: 15 minutes  
Dirt conditions

## MULTI ACTIV | Unscented



Ready-to-use disinfectant for surfaces according to **Italian Ministry of Health**, Registration no. 20058.

- Eliminates 99.9% of bacteria, fungi and viruses
- Cleans and eliminates bad odours
- Effectively removes gram-positive and gram-negative bacteria, fungi, moulds, and both enveloped and non-enveloped viruses from smooth surfaces, thanks to its formulation with active ingredients
- Suitable for disinfecting kitchens, bathrooms and all surfaces in contact with food

**Directions:** For normal cleaning, apply directly to the surface to be treated and then dry with a cloth or paper. For disinfection, leave on for at least 5 minutes to obtain bactericidal action or for at least 15 minutes to also obtain fungicidal and virucidal action. For virucidal action, apply the product to the previously cleaned surface. When disinfecting surfaces that may come into direct contact with food, rinse with potable water.

**Dosage:** See the terms of use in the table.



Code	1821-S	Pcs x Box	6
EAN	8032680391446	Box x Lyr	21
Volume	750 ml	Box x Plt	105



View the data sheet on your smartphone.

### Active ingredient

Alkyl dimethylbenzyl ammonium chloride 0.4 g/100 g

## MULTI ACTIV | Lemon



Ready-to-use disinfectant for surfaces according to **Italian Ministry of Health**, Registration no. 20058.

- Eliminates 99.9% of bacteria, fungi and viruses
- Cleans and eliminates bad odours
- Effectively removes gram-positive and gram-negative bacteria, fungi, moulds, and both enveloped and non-enveloped viruses from smooth surfaces, thanks to its formulation with active ingredients
- Suitable for disinfecting kitchens, bathrooms and all surfaces in contact with food

**Directions:** For normal cleaning, apply directly to the surface to be treated and then dry with a cloth or paper. For disinfection, leave on for at least 5 minutes to obtain bactericidal action or for at least 15 minutes to also obtain fungicidal and virucidal action. For virucidal action, apply the product to the previously cleaned surface. When disinfecting surfaces that may come into direct contact with food, rinse with potable water.

**Dosage:** See the terms of use in the table.



Code	1838-S	Pcs x Box	6
EAN	8054633838013	Box x Lyr	21
Volume	750 ml	Box x Plt	105



View the data sheet on your smartphone.

### Active ingredient

Alkyl dimethylbenzyl ammonium chloride 0.4 g/100 g

## MULTI ACTIV | Pine



Ready-to-use disinfectant for surfaces according to **Italian Ministry of Health**, Registration no. 20058.

- Eliminates 99.9% of bacteria, fungi and viruses
- Cleans and eliminates bad odours
- Effectively removes gram-positive and gram-negative bacteria, fungi, moulds, and both enveloped and non-enveloped viruses from smooth surfaces, thanks to its formulation with active ingredients
- Suitable for disinfecting kitchens, bathrooms and all surfaces in contact with food

**Directions:** For normal cleaning, apply directly to the surface to be treated and then dry with a cloth or paper. For disinfection, leave on for at least 5 minutes to obtain bactericidal action or for at least 15 minutes to also obtain fungicidal and virucidal action. For virucidal action, apply the product to the previously cleaned surface. When disinfecting surfaces that may come into direct contact with food, rinse with potable water.

**Dosage:** See the terms of use in the table.



Code	1822-S	Pcs x Box	6
EAN	8032680392009	Box x Lyr	21
Volume	750 ml	Box x Plt	105



View the data sheet on your smartphone.

### Active ingredient

Alkyl dimethylbenzyl ammonium chloride 0.4 g/100 g



**Product code** 1821-S, 1838-S, 1822-S

**Active ingredient** Alkyl dimethylbenzyl ammonium chloride 0.4 g/100 g

### Bactericidal efficacy

### Fungicidal efficacy

### Virucidal efficacy

### Regulation

UNI EN 1276:2009  
UNI EN 13697:2015

UNI EN 1650:2008  
UNI EN 13697:2001

UNI EN 14476:2019  
UNI EN 16777:2019

### Tested organisms

Pseudomonas aeruginosa  
Staphylococcus aureus  
Enterococcus hirae  
Escherichia coli

Candida albicans  
Penicillium verrucosum

Vaccinia virus  
Adenovirus type 5,  
Murine norovirus MNV

### Conditions of use

Concentration: Ready to use  
Contact time: 5 minutes  
Dirt conditions

Concentration: Ready to use  
Contact time: 15 minutes  
Dirt conditions

Concentration: Ready to use  
Contact time: 15 minutes  
Clean conditions

Concentrated disinfectant for surfaces according to **Italian Ministry of Health**, Registration no. 20047



- Eliminates 99.9% of bacteria, fungi and viruses
- Fungicidal, bactericidal and virucidal action, active against gram-positive and gram-negative bacteria, fungi, moulds and viruses, both enveloped and non-enveloped, present in domestic and professional environments
- Particularly suitable for disinfecting surfaces and equipment in the agri-food, hotel and catering industries
- It is also suitable for use in high traffic environments, such as bathrooms in public places, outpatient clinics and hospital environments

**Directions:** Dilute SANIMED® in water and spray or spread with a sponge or mop. For small utensils, immerse the material to be disinfected. When disinfecting surfaces that may come into direct contact with food, rinse with potable water. For virucidal action, apply the product to the previously cleaned surface, in a 5% solution equal to 250 ml per 5 litres of water.

**Dosage:** For normal cleaning dilute SANIMED® at 0.5%, equal to 25 ml per 5 litres of water. For disinfection, dilute SANIMED® at 1.5%, equal to 75 ml per 5 litres of water and leave to act for at least 5 minutes for bactericidal activity or at least 15 minutes for fungicidal and virucidal activity.



Code	<b>1511</b>	Pcs x Box	2
EAN	8032680391248	Box x Lyr	18
Volume	5 L / 5 kg	Box x Pli	72



View the data sheet on your smartphone.

**Active ingredient**

Alkyl dimethylbenzyl ammonium chloride 10 g/100 g



**Product code** 1511

**Active ingredient** Alkyl dimethylbenzyl ammonium chloride 10 g/100 g

	<b>Bactericidal efficacy</b>	<b>Fungicidal efficacy</b>	<b>Virucidal efficacy</b>
<b>Regulation</b>	UNI EN 1276:2009 UNI EN 13697:2015	UNI EN 1650:2008 UNI EN 13697:2001	UNI EN 14476:2019 UNI EN 16777:2019
<b>Tested organisms</b>	Pseudomonas aeruginosa Staphylococcus aureus Enterococcus hirae Escherichia coli	Candida albicans Penicillium verrucosum	Vaccinia virus Adenovirus type 5, Murine norovirus MNV
<b>Conditions of use</b>	Concentration: 1.5% Contact time: 5 minutes Dirt conditions	Concentration: 1.5% Contact time: 15 minutes Dirt conditions	Concentration: 5% Contact time: 15 minutes Clean conditions

## BAKTERIO | Balsamic pine



Concentrated disinfectant for surfaces according to **Italian Ministry of Health**, Registration no. 15446.

- Disinfects, cleans and deodorizes
- Removes all traces of dirt and eliminates bad odours
- It leaves a pleasant scent
- Safe on metals, does not stain surfaces

**Directions:** BAKTERIO® should be used with a cloth or sponge soaked in the solution to disinfect, clean and deodorise rooms and objects in hotels, canteens, industries, schools, retirement homes, etc.

**Dosage:** To disinfect and deodorize bathrooms, sinks, walls, floors, tiles, waste containers, toilet bowls and other surfaces, potential sources of germs, dilute BAKTERIO® in water at a ratio of 20%, leaving it on for 15 minutes. For ordinary disinfection and cleaning of bathrooms, sinks, walls, floors, tiles, doors, doorposts and other washable surfaces, dilute BAKTERIO® in water from 1 to 3% leaving it on for 5 minutes.



**Active ingredient**

Alkyl dimethylbenzyl ammonium chloride 3 g/100 g



Code	<b>1540N-S</b>	Pcs x Box	6
EAN	8032680392719	Box x Lyr	21
Volume	1000 ml	Box x Plt	105



View the data sheet on your smartphone.



Code	<b>1541</b>	Pcs x Box	2
EAN	8032680392726	Box x Lyr	18
Volume	5 L / 5 kg	Box x Plt	72



View the data sheet on your smartphone.

## BAKTERIO | Lime



Concentrated disinfectant for surfaces according to **Italian Ministry of Health**, Registration no. 15446.

- Disinfects, cleans and deodorizes
- Removes all traces of dirt and eliminates bad odours
- It leaves a pleasant scent
- Safe on metals, does not stain surfaces

**Directions:** BAKTERIO® should be used with a cloth or sponge soaked in the solution to disinfect, clean and deodorise rooms and objects in hotels, canteens, industries, schools, retirement homes, etc.

**Dosage:** To disinfect and deodorize bathrooms, sinks, walls, floors, tiles, waste containers, toilet bowls and other surfaces, potential sources of germs, dilute BAKTERIO® in water at a ratio of 20%, leaving it on for 15 minutes. For ordinary disinfection and cleaning of bathrooms, sinks, walls, floors, tiles, doors, doorposts and other washable surfaces, dilute BAKTERIO® in water from 1 to 3% leaving it on for 5 minutes.



**Active ingredient**

Alkyl dimethylbenzyl ammonium chloride 3 g/100 g



Code	<b>1544</b>	Pcs x Box	2
EAN	8032680393921	Box x Lyr	18
Volume	5 L / 5 kg	Box x Plt	72



View the data sheet on your smartphone.



**Product code** 1540N-S, 1541, 1544, 1713

**Active ingredient** Alkyl dimethylbenzyl ammonium chloride 3 g/100 g

**Bactericidal efficacy**

**Fungicidal efficacy**

**Virucidal efficacy**

**Regulation**

UNI EN 1276:2009  
UNI EN 13697:2001

UNI EN 1650:2008  
UNI EN 13697:2001

UNI EN 14476:2019  
UNI EN 16777:2019

**Tested organisms**

Pseudomonas aeruginosa  
Staphylococcus aureus  
Enterococcus hirae  
Escherichia coli

Candida albicans  
Penicillium verrucosum

Vaccinia virus  
Adenovirus type 5,  
Murine norovirus MNV

**Conditions of use**

Concentration: 5%  
Contact time: 5 minutes  
Dirt conditions

Concentration: 5%  
Contact time: 15 minutes  
Dirt conditions

Concentration: 20%  
Contact time: 15 minutes  
Clean conditions

# SANI GEL MED



Alcohol-based hand sanitizer without rinsing, according to **Italian Ministry of Health**, Registration no. 20832

- Hydroalcoholic disinfectant for skin antiseptics
- Eliminates 99.9% of bacteria, fungi and viruses within 60 seconds
- With moisturising agents
- It can be used in any environment: healthcare, institutional, industrial and domestic

**Directions:** Dose the product on the palm in a quantity suitable for rubbing for at least 60 seconds, distributing it over all parts of the hand. The product is used without water and does not need to be rinsed.

**Dosage:** Ready to use. For surgical hand disinfection, apply the product for 180 seconds, spreading it evenly over the entire hand and forearm.

Support accessories on page 127

pH  
6 - 7



Code	<b>1035</b>	Pcs x Box	6
EAN	8054633839423	Box x Lyr	20
Volume	600 ml	Box x Plt	140



View the data sheet on your smartphone.



Code	<b>1036</b>	Pcs x Box	2
EAN	8054633839430	Box x Lyr	18
Volume	5 L / 4.4 kg	Box x Plt	72



View the data sheet on your smartphone.



**Product code** 1035, 1036

**Active ingredient** Ethanol 70.1 g/100g

## Bactericidal efficacy

## Fungicidal efficacy

## Virucidal efficacy

### Regulation

UNI EN 13727: 2015  
UNI EN 1500: 2013

UNI EN 13624: 2013

UNI EN 14476:2019

### Tested organisms

Pseudomonas aeruginosa  
Staphylococcus aureus  
Enterococcus hirae  
Escherichia coli K12

Candida albicans  
Aspergillus brasiliensis

Adenovirus type 5,  
Murine norovirus MNV  
Poliovirus

### Conditions of use

Concentration: ready to use  
Contact time: 60 seconds

Concentration: ready to use  
Contact time: 60 seconds

Concentration: ready to use  
Contact time: 60 seconds

# SECURGERM MED



Hand sanitizer soap, according to **Italian Ministry of Health**, Registration no. 21457

- Handwash disinfectant for use whenever thorough skin disinfection is required
- Eliminates 99.9% of bacteria and yeasts

**Directions:** Dose the product on the palm of the hand and wash for 60 seconds. Rinse thoroughly and dry.  
**Dosage:** Ready to use.

pH 5 - 6





Code	<b>1027</b>	Pcs x Box	6
EAN	8050999571618	Box x Lyr	15
Volume	1000 ml	Box x Pkt	90



View the data sheet on your smartphone.



Code	<b>1028</b>	Pcs x Box	2
EAN	8050999571625	Box x Lyr	18
Volume	5 L / 5 kg	Box x Pkt	72



View the data sheet on your smartphone.



**Product code** 1027, 1028

**Active ingredient** Alkyl dimethylbenzyl ammonium chloride 0.75 g / 100 g - 2-phenoxyethanol 0.9 g / 100 g

**Bactericidal efficacy**

**Fungicidal efficacy**

**Virucidal efficacy**

**Regulation**

EN 13727:2012+A2:2015  
EN 1499:2013

EN 13624:2013

14476:2013 + A2:2019

**Tested organisms**

Pseudomonas aeruginosa  
Staphylococcus aureus  
Escherichia coli K12  
Salmonella enterica  
Listeria monocytogenes  
Proteus mirabilis

Candida albicans  
Aspergillus brasiliensis

Modified Vaccinia virus Ankara

**Conditions of use**

Concentration: Ready to use  
Contact time: 5 minutes  
Dirt conditions

Concentration: Ready to use  
Contact time: 15 minutes  
Dirt conditions

Concentration: Ready to use  
Contact time: 15 minutes  
Dirt conditions



## DISINFECTION KIT

A complete line of disinfectant products according to **Italian Ministry of Health** to meet every professional need



Code **1006-S**  
EAN IC 18050999572032



### SECURGERM MED

Code **1027**  
EAN 8050999571618  
Pack 1 pcs x 1000 ml

Product details on page 128



### MULTI ACTIV

Code **1821-S**  
EAN 8032680391446  
Pack 1 pcs x 750 ml

Product details on page 33



### MULTI ACTIV

Code **1822-S**  
EAN 8032680392009  
Pack 1 pcs x 750 ml

Product details on page 34



### BAKTERIO

Code **1540N-S**  
EAN 8032680392719  
Pack 1 pcs x 1000 ml

Product details on page 59



### SANI ACTIVE

Code **1804-S**  
EAN 8054633834602  
Pack 1 pcs x 750 ml

Product details on page 33



### CHLOR WC GEL

Code **1944**  
EAN 8050999570697  
Pack 1 pcs x 700 ml

Product details on page 71

# ALPHABETICAL INDEX

PRODUCT NAME	CODE	PAGE
ACID SP 5 LT	7007	142
ACTIVE CHLOR 5 LT	1173	37 - 56 - 69
ACTIVE CHLOR FOAM 750 ML	1560-S	37 - 69
ACTIVE CHLOR GEL 1 LT	1562-S	37 - 69
ACTIVE CHLOR TABLET	2122	38 - 56 - 70
ACTIVE OXYGEN 5 LT	1174	38 - 56 - 70
ACTIVE OXYGEN FOAM 750 ML	1175-S	38
ALGHICIDA 5 LT	2609	155
ANTI CHLOR 5 LT	2618	154
AQUA 5 LT	7005	143
AQUA PLUS 5 LT	7008	143
ATOMIC POWER 12 KG	2087	117
ATOMIC ULTRA 12 KG	2086	117
BAKTERIO LIME 5 LT	1544	59 - 174
BAKTERIO PINE 1 LT	1540N-S	59 - 174
BAKTERIO PINE 5 LT	1541	59 - 174
BARRIER CREAM 150 ML	6020	133
BIO BACT 5 LT	2410	72
BIO URISCREEN	2430	73
BLU POWER WC GEL	1946	71
BLUE CLOTH	273	87
BRILL GREEN POWER 15 LT	4020	24 - 161
BRILL GREEN POWER 5 LT	4019	24 - 161
BRILL LUX 5 LT	1415	60
BRILL OSMOS LT 5	1191	25
BRILL OVEN 5 LT	1967	41
BRILL POWER 15 LT	1134	25
BRILL POWER 5 LT	1130	25
BRILL ULTRA 15 LT	1153	24
BRILL ULTRA 5 LT	1150	24
CAFFE' WASH 800 ML	2161	41
CHLOR WC GEL 700 ML	1944	71
CLEANSING OIL 300 ML	6031	131
CREAM SOAP BLUE IRIS 1 LT	1020	124
CREAM SOAP BLUE IRIS 5 LT	1021	124
CREAM SOAP GOLD ARGAN 5 LT	2018	124
CREAM SOAP GREEN ALOE 1 LT	1080	124
CREAM SOAP GREEN ALOE 5 LT	1081	124
CRYSTAL 5 LT	2261	74
CRYSTAL 750 ML	1866-S	74
CRYSTAL GREEN POWER 750 ML	3102	74 - 164
DEGREASER ULTRA LEMON 5 LT	1801	36 - 75
DEGREASER ULTRA LEMON 750 ML	1810-S	36 - 75
DEGREASER ULTRA MARSEILLE 5 LT	1809	36 - 75
DEGREASER ULTRA MARSEILLE 750 ML	1808-S	36 - 75
DEINK 5 LT	1887	79
DEINK 750 ML	1884-S	79
DEKAL 5 LT	1950	30
DEKAL GREEN POWER 5 LT	3113	30 - 162
DEO FRESH FLOWER BOUQUET 750 ML	2303	95
DEO FRESH GOLD ARGAN 750 ML	2301	94
DEO FRESH IRIS 750 ML	2304	95
DEO FRESH PEACH & GREEN APPLE 750 ML	2305	95
DEO FRESH PINE & JUNIPER 750 ML	2302	95
DEO FRESH WHITE MUSK 750 ML	2300	94
DEO SPRAY BERGAMOT & JASMINE 300 ML	2402	97
DEO SPRAY FLOWER BOUQUET 300 ML	2403	97
DEO SPRAY GOLD ARGAN 300 ML	2401	96
DEO SPRAY PEACH & GREEN APPLE 300 ML	2404	97
DEO SPRAY WHITE MUSK 300 ML	2400	96
DEO SURFACE FLOWER BOUQUET 5 LT	2204	51 - 93
DEO SURFACE FRESH CITRUS 5 LT	2202	51 - 93
DEO SURFACE GOLD ARGAN 5 LT	2201	50 - 92
DEO SURFACE PEACH & GREEN APPLE 5 LT	2205	51 - 93
DEO SURFACE PINE & JUNIPER 5 LT	2203	51 - 93
DEO SURFACE WHITE MUSK 5 LT	2200	50 - 92

PRODUCT NAME	CODE	PAGE
DEO WC GEL 700 ML	1943	71
DETERGENT KIT	1007-S	84
DICHLOR 56% 25 KG	2607	154
DICHLOR 56% 5 KG	2613	154
DISINFECTION KIT	1006-S	86
DISPENSER FOR TANK 5 LT	12388	129 - 150
DOSY CABINET FOR BOTTLE	213	83
DOSY CABINET FOR BUCKET	214	83
DRIP TRAY SUPPORT	317	127
EMULSI ACID 15 LT	1858	149
EMULSI CHLOR 15 LT	1859	148
EMULSI CIP 15 LT	2142	148
EMULSI FOAM 15 LT	1852	148
EMULSI HYPOCHLOR 15 LT	1863	149
EMULSI KAL 15 LT	1856	149
FLOCCULANT 15 LT	2616	155
FLOOR ACID 5 LT	1460	55
FORNONET 5 LT	1961	40
FORNONET 750 ML	1960-S	40
FRYDET TABLET 500 G	2131	39
GRAFFITI RM 5 LT	7004	141
GREEN CLOTH	276	87
GREEN POWER KIT	1005-S	85 - 167
GREKOL SS 5 LT	1815	42
HAND WASH SHEA 5 LT	1050	125
HC10 BAKTERIO 1 LT	1713	81
HC2A IGIENIKAL 1 LT	1703	82
HC3 CRYSTAL 1 LT	1705	82
HC4 SURFACE 1 LT	1706	81
HC9 DEGRI 1 LT	1709	82
HYDRO S 5 LT	7006	144
IGIENIC FLOOR GREEN APPLE 1 LT	1434-S	52
IGIENIC FLOOR GREEN APPLE 5 LT	1437	52
IGIENIC FLOOR LAVENDER 5 LT	1436	53
IGIENIC FLOOR MINT & LEMON 5 LT	1410	53
IGIENIC FLOOR ORANGE BLOSSOM 1 LT	1433-S	52
IGIENIC FLOOR ORANGE BLOSSOM 5 LT	1435	52
IGIENIC FLOOR PEACH 5 LT	1439	53
IGIENIKAL BALSAMIC 5 LT	1931	66
IGIENIKAL BALSAMIC 750 ML	1930-S	66
IGIENIKAL GREEN POWER 750 ML	3103	66 - 163
IGIENIKAL ORCHID 750 ML	1920-S	66
INDUCTION HOBBS 500 ML	1836	42
INDUSTRIAL SOAP 1 LT	1040	129 - 150
INDUSTRIAL SOAP 5 LT	1045	129 - 150
INOX 750 ML	1875-S	43 - 78
INTIMATE WASH 250 ML	6014	131
KIT HC10 SURFACE DISINFECTANT	1713KIT	83
KIT HC2A LIMESCALE REMOVER	1703KIT	83
KIT HC3 GLASS MIRRORS AND DUSTING	1705KIT	83
KIT HC4 FLOOR CLEANER	1706KIT	83
KIT HC9 SURFACE DEGREASER	1709KIT	83
LAUNDRY BASIC 15 LT	2077	107
LAUNDRY NEUTRALIZER 15 LT	2046	111
LAUNDRY SOFT MEDITERRANEAN FLOWERS 15 LT	2071	110
LAUNDRY SOFT WHITE MUSK 15 LT	2072	111
LAUNDRY SURF 15 LT	2076	108
L-BRAIN CONNECT CONTROL UNIT	240	112
LEATHER 500 ML	1835	79
LIQUID CHLOR 15 LT	2082	154
LIQUID SOAP GREEN POWER 1 LT	4015	123 - 166
LIQUID SOAP GREEN POWER 5 LT	4006	123 - 166
MATIC EXTRA 5 LT	1445	54
MATIC FLOOR 5 LT	1440	54
METAL BRO 5 LT	7003	141
MOQUETTE 5 LT	1450	60
MOUSSE SOAP AUTOMATIC DISPENSER	266	125
MOUSSE SOAP GREEN POWER 5 LT	1091	123 - 166
MOUSSE SOAP GREEN POWER 600 ML	4005	123 - 166

PRODUCT NAME	CODE	PAGE	PRODUCT NAME	CODE	PAGE
MOUSSE SOAP GREEN POWER 800 ML	1061	123 - 166	SOAP AND GEL AUTOMATIC DISPENSER	249	125
MOUSSE SOAP MANUAL DISPENSER	265	125	SOAP AND GEL MANUAL DISPENSER	247	125
MULTI ACTIV FRAGRANCE FREE 750 ML	1821-S	33 - 76 - 171	SOFT EMULSION 600 ML	6011	132
MULTI ACTIV LEMON 750 ML	1838-S	34 - 68 - 76 - 172	SOFT SHAMPOO 600 ML	6013	131
MULTI ACTIV PI NE 750 ML	1822-S	34 - 68 - 77 - 172	SOFT SHOWER GEL 600 ML	6012	130
NATURAL 5 LT	2100	43	SOFTDET BLUE ORCHID 15 LT	2092	117
NEOPOL CITRUS 1 LT	1231	31	SOFTDET BLUE ORCHID 5 LT	2091	117
NEOPOL CITRUS 5 LT	1230	31	SOFTDET GREEN POWER 5 LT	3110	116
NEOPOL GREEN POWER 1 LT	3106	31 - 161	SOFTDET ROSE PETALS 5 LT	SN2062	116
NEOPOL GREEN POWER 5 LT	3104	31 - 161	SOFTDET WHITE MUSK 5 LT	2060	116
NEOPOL LEMON 1 LT	1271	32	SPRAY MAXI PER TANICA 5 L	60	40
NEOPOL LEMON 5 LT	1270	32	STAND FOR AUTOMATIC DISPENSER	318	127
NEUTRO FLOOR 1 LT	1481-S	53	STEEL PRO 500 ML	1813	42 - 78
NEUTRO FLOOR 5 LT	1480	53	STOVIL ACTIVE 15 LT	1103	22
OVEN POWER 5 LT	1965	41	STOVIL ACTIVE 5 LT	1100	22
PARQUET 1 LT	1471-S	60	STOVIL BAR 5 LT	1110	23
PARQUET 5 LT	1470	60	STOVIL CHLOR 15 L	1168	22
PERISTALTIC DISPENSER FOR DETERGENT	5	25	STOVIL CHLOR 5 L	1172	22
PERISTALTIC DISPENSER FOR RINSE AID	6	26	STOVIL FAST 5 LT	1166	23
PERISTALTIC PUMP FOR DETERGENT	371	26	STOVIL GEL 1 LT	1161-S	24
PERISTALTIC PUMP FOR RINSE AID	372	26	STOVIL GEL 5 LT	1104	24
PETRA 24 15 LT	7001	140	STOVIL GREEN POWER 15 L	4018	21 - 161
PH- 15 LT	2617	156	STOVIL GREEN POWER 5 L	4017	21 - 161
PH+ 15 LT	2615	155	STOVIL OSMOS 15 L	1180	22
POWER XP 5 LT	7002	140	STOVIL POWER 15 LT	1123	21
PRECIOUS OIL 300 ML	6033	132	STOVIL POWER 5 LT	1120	21
PROMAX DILUTER 4 BOTTLES	91	57	STOVIL TABS 60 PZ	1160	23
PROMAX DILUTER 4 BUCKETS	68	57	STOVIL ULTRA 15 LT	1144	21
PROMAX DILUTER 1 BOTTLE	90	57	STOVIL ULTRA 5 LT	1140	21
PROMAX DILUTER 1 BUCKET	18	57	SURFACE GREEN POWER 1 LT	3109-S	51 - 163
PULIACID 1 LT	1491	55	TANK HOLDER BRACKET	11847	29 - 112
QUANTUM BASIC 15 LT	2077HC	107 - 164	TOTAL BODY 1 LT	6030	130
QUANTUM BASIC 5 LT	2051HC	107 - 164	TOTAL BODY 500 ML	3210	130
QUANTUM BOOSTER 5 LT	2090HC	109	TOTAL BODY SOFT MOUSSE 600 ML	3211	130
QUANTUM CHLOR 15 LT	2078HC	108	TRILOGY BOOST T2 5 LT	4013	28
QUANTUM CHLOR 5L	2053HC	108	TRILOGY CONTROL UNIT	370	29
QUANTUM OXYGEN 15 LT	2049HC	108 - 165	TRILOGY RINSE T3 5 LT	4014	28
QUANTUM OXYGEN 5 LT	2050HC	108 - 165	TRILOGY WASH T1 5 LT	4012	28
QUANTUM PERACETIC 15 LT	2073HC	109	ULTRA DEGREASER GREEN POWER 750 ML	3101	36 - 74 - 162
QUANTUM PERACETIC 5 LT	2054HC	109	ULTRAKAL 750 ML	1910-S	67
QUANTUM SOFT ARGAN 5 LT	2083HC	110	UNBLOCKER GEL 1 LT	1980	72
QUANTUM SOFT ECO 5 LT	2065HC	109	URI DEO MANGO	2431	73
QUANTUM SOFT MEDITERRANEAN FLOWERS 15 LT	2071HC	110 - 165	URI DEO MINT	2432	73
QUANTUM SOFT MEDITERRANEAN FLOWERS 5 LT	2064HC	110 - 165	URI TABS 3 KG	2150	72
QUANTUM SURF 15 LT	2076HC	107 - 164	WALL BRACKET FOR BOTTLE	306A	127
QUANTUM SURF 5 LT	2052HC	107 - 164	WASH CREAM 600 ML	6010	132
RED CLOTH	274	87	WASHDET BLUE ORCHID 15 LT	2038	115
RIGHT DOSE CAP	1716-S	83	WASHDET BLUE ORCHID 5 LT	2034	115
RUDERAL 5 LT	1976	156	WASHDET EXTRA 5 LT	2023	115
SANI ACTIVE 750 ML	1804-S	33 - 171	WASHDET GREEN POWER 5 LT	3112	114 - 165
SANI CITRIC 1 LT	1913-S	67	WASHDET ROSE PETALS 5 LT	SN2026	114
SANI GEL MED 5 LT	1036	126 - 175	WASHDET WHITE MUSK 5 LT	2025	114
SANI GEL MED 600 ML	1035	126 - 175	WASHUP GREEN LEMON 1 LT	1242-S	32
SANI NEOPOL 1 LT	1274	31	WASHUP POWDER GREEN LEMON 8 KG	1291	32
SANI NEOPOL 5 LT	1276	31	WASHUP GREEN LEMON 5 LT	1240	32
SANIALC 750 ML	1830-S	39 - 75	WC GEL GREEN POWER 700 ML	1945	70 - 163
SANIALC FLOORS 1 LT	1426N-S	57	WOOD 500 ML	1834	79
SANIALC FLOORS 5 LT	1425	57	WOOLDET 5 LT	2030	115
SANIALC ULTRA 5 LT	1842	39	WX1 METALIZED WAX 5 LT	1610	61
SANIALC ULTRA 750 ML	1841-S	39	WX2 WAX REMOVER 5 LT	1660	61
SANIFORM 1 LT	1520N-S	57	WX3 WAX&CLEAN 5 LT	1640	61
SANIFORM 5 LT	1521	57	X1 OXY REMOVER 500 ML	1814	118
SANIMED 5 LT	1511	35 - 58 - 173	X2 GREASE REMOVER 500 ML	1816	118
SECURGERM MED 5 LT	1028	128 - 176	X3 SOLV REMOVER 500 ML	1817	118
SECURGERM MED MOUSSE 600 ML	1029	128	X4 RUST REMOVER 500 ML	1819	119
SECURGERM MED 1 LT	1027	128 - 176	YELLOW CLOTH	275	87
SILVER 5 LT	1881	43 - 78			
SIRPAV 1 LT	1421-S	54			
SIRPAV HC 5 LT	1422	55			

# PRODUCT CODE INDEX

CODE	PRODUCT NAME	PAGE	CODE	PRODUCT NAME	PAGE
5	PERISTALTIC DISPENSER FOR DETERGENT	25	1231	NEOPOL CITRUS 1 LT	31
6	PERISTALTIC DISPENSER FOR RINSE AID	26	1240	WASHUP GREEN LEMON 5 LT	32
18	PROMAX DILUTER 1 BUCKET	57	1242-S	WASHUP GREEN LEMON 1 LT	32
60	SPRAY MAXI FOR CAN 5 L	40	1270	NEOPOL LEMON 5 LT	32
68	PROMAX DILUTER 4 BUCKETS	57	1271	NEOPOL LEMON 1 LT	32
90	PROMAX DILUTER 1 BOTTLE	57	1274	SANI NEOPOL 1 LT	31
91	PROMAX DILUTER 4 BOTTLES	57	1276	SANI NEOPOL 5 LT	31
213	DOSY CABINET FOR BOTTLE	83	1291	WASHUP POWDER GREEN LEMON 8 KG	32
214	DOSY CABINET FOR BUCKET	83	1410	IGIENIC FLOOR MINT & LEMON 5 LT	53
240	L-BRAIN CONNECT CONTROL UNIT	112	1415	BRILL LUX 5 LT	60
247	SOAP AND GEL MANUAL DISPENSER	125	1421-S	SIRPAV 1 LT	54
249	SOAP AND GEL AUTOMATIC DISPENSER	125	1422	SIRPAV HC 5 LT	55
265	MOUSSE SOAP MANUAL DISPENSER	125	1425	SANIALC FLOORS 5 LT	57
266	MOUSSE SOAP AUTOMATIC DISPENSER	125	1426N-S	SANIALC FLOORS 1 LT	57
273	BLUE CLOTH	87	1433-S	IGIENIC FLOOR ORANGE BLOSSOM 1 LT	52
274	RED CLOTH	87	1434-S	IGIENIC FLOOR GREEN APPLE 1 LT	52
275	YELLOW CLOTH	87	1435	IGIENIC FLOOR ORANGE BLOSSOM 5 LT	52
276	GREEN CLOTH	87	1436	IGIENIC FLOOR LAVENDER 5 LT	53
306A	WALL BRACKET FOR BOTTLE	127	1437	IGIENIC FLOOR GREEN APPLE 5 LT	52
317	DRIP TRAY SUPPORT	127	1439	IGIENIC FLOOR PEACH 5 LT	53
318	STAND FOR AUTOMATIC DISPENSER	127	1440	MATIC FLOOR 5 LT	54
370	TRILOGY CONTROL UNIT	29	1445	MATIC EXTRA 5 LT	54
371	PERISTALTIC PUMP FOR DETERGENT	26	1450	MOQUETTE 5 LT	60
372	PERISTALTIC PUMP FOR RINSE AID	26	1460	FLOOR ACID 5 LT	55
1005-S	GREEN POWER KIT	85 - 167	1470	PARQUET 5 LT	60
1006-S	DISINFECTION KIT	86	1471-S	PARQUET 1 LT	60
1007-S	DETERGENT KIT	84	1480	NEUTRO FLOOR 5 LT	53
1020	CREAM SOAP BLUE IRIS 1 LT	124	1481-S	NEUTRO FLOOR 1 LT	53
1021	CREAM SOAP BLUE IRIS 5 LT	124	1491	PULIACID 1 LT	55
1027	SECURGERM MED 1 LT	128 - 176	1511	SANIMED 5 LT	35 - 58 - 173
1028	SECURGERM MED 5 LT	128 - 176	1520N-S	SANIFORM 1 LT	57
1029	SECURGERM MED MOUSSE 600 ML	128	1521	SANIFORM 5 LT	57
1035	SANI GEL MED 600 ML	126 - 175	1540N-S	BAKTERIO PINE 1 LT	59 - 174
1036	SANI GEL MED 5 LT	126 - 175	1541	BAKTERIO PINE 5 LT	59 - 174
1040	INDUSTRIAL SOAP 1 LT	129 - 150	1544	BAKTERIO LIME 5 LT	59 - 174
1045	INDUSTRIAL SOAP 5 LT	129 - 150	1560-S	ACTIVE CHLOR FOAM 750 ML	37 - 69
1050	HAND WASH SHEA 5 LT	125	1562-S	ACTIVE CHLOR GEL 1 LT	37 - 69
1061	MOUSSE SOAP GREEN POWER 800 ML	123 - 166	1610	WX1 METALIZED WAX 5 LT	61
1080	CREAM SOAP GREEN ALOE 1 LT	124	1640	WX3 WAX&CLEAN 5 LT	61
1081	CREAM SOAP GREEN ALOE 5 LT	124	1660	WX2 WAX REMOVER 5 LT	61
1091	MOUSSE SOAP GREEN POWER 5 LT	123 - 166	1703	HC2A IGIENIKAL 1 LT	82
1100	STOVIL ACTIVE 5 LT	22	1703KIT	KIT HC2A LIMESCALE REMOVER	83
1103	STOVIL ACTIVE 15 LT	22	1705	HC3 CRYSTAL 1 LT	82
1104	STOVIL GEL 5 LT	24	1705KIT	KIT HC3 GLASS MIRRORS AND DUSTING	83
1110	STOVIL BAR 5 LT	23	1706	HC4 SURFACE 1 LT	81
1120	STOVIL POWER 5 LT	21	1706KIT	KIT HC4 FLOOR CLEANER	83
1123	STOVIL POWER 15 LT	21	1709	HC9 DEGRI 1 LT	82
1130	BRILL POWER 5 LT	25	1709KIT	KIT HC9 SURFACE DEGREASER	83
1134	BRILL POWER 15 LT	25	1713	HC10 BAKTERIO 1 LT	81
1140	STOVIL ULTRA 5 LT	21	1713KIT	KIT HC10 SURFACE DISINFECTANT	83
1144	STOVIL ULTRA 15 LT	21	1716-S	RIGHT DOSE CAP	83
1150	BRILL ULTRA 5 LT	24	1801	DEGREASER ULTRA LEMON 5 LT	36 - 75
1153	BRILL ULTRA 15 LT	24	1804-S	SANI ACTIVE 750 ML	33 - 171
1160	STOVIL TABS 60 PZ	23	1808-S	DEGREASER ULTRA MARSEILLE 750 ML	36 - 75
1161-S	STOVIL GEL 1 LT	24	1809	DEGREASER ULTRA MARSEILLE 5 LT	36 - 75
1166	STOVIL FAST 5 LT	23	1810-S	DEGREASER ULTRA LEMON 750 ML	36 - 75
1168	STOVIL CHLOR 15 L	22	1813	STEEL PRO 500 ML	42 - 78
1172	STOVIL CHLOR 5 L	22	1814	X1 OXY REMOVER 500 ML	118
1173	ACTIVE CHLOR 5 LT	37 - 56 - 69	1815	GREKOL SS 5 LT	42
1174	ACTIVE OXYGEN 5 LT	38 - 56 - 70	1816	X2 GREASE REMOVER 500 ML	118
1175-S	ACTIVE OXYGEN FOAM 750 ML	38	1817	X3 SOLV REMOVER 500 ML	118
1180	STOVIL OSMOS LT 5	22	1819	X4 RUST REMOVER 500 ML	119
1191	BRILL OSMOS LT 5	25	1821-S	MULTI ACTIV FRAGRANCE FREE 750 ML	33 - 76 - 171
1230	NEOPOL CITRUS 5 LT	31	1822-S	MULTI ACTIV PINE 750 ML	34 - 68 - 77 - 172
			1830-S	SANIALC 750 ML	39 - 75
			1834	WOOD 500 ML	79
			1835	LEATHER 500 ML	79
			1836	INDUCTION HOBBS 500 ML	42
			1838-S	MULTI ACTIV LEMON 750 ML	34 - 68 - 76 - 172

CODE	PRODUCT NAME	PAGE	CODE	PRODUCT NAME	PAGE
1841-S	SANIALC ULTRA 750 ML	39	2203	DEO SURFACE PINE & JUNIPER 5 LT	51 - 93
1842	SANIALC ULTRA 5 LT	39	2204	DEO SURFACE FLOWER BOUQUET 5 LT	51 - 93
1852	EMULSI FOAM 15 LT	148	2205	DEO SURFACE PEACH & GREEN APPLE 5 LT	51 - 93
1856	EMULSI KAL 15 LT	149	2261	CRYSTAL 5 LT	74
1858	EMULSI ACID 15 LT	149	2300	DEO FRESH WHITE MUSK 750 ML	94
1859	EMULSI CHLOR 15 LT	148	2301	DEO FRESH GOLD ARGAN 750 ML	94
1863	EMULSI HYPOCHLOR 15 LT	149	2302	DEO FRESH PINE & JUNIPER 750 ML	95
1866-S	CRYSTAL 750 ML	74	2303	DEO FRESH FLOWER BOUQUET 750 ML	95
1875-S	INOX 750 ML	43 - 78	2304	DEO FRESH IRIS 750 ML	95
1881	SILVER 5 LT	43 - 78	2305	DEO FRESH PEACH & GREEN APPLE 750 ML	95
1884-S	DEINK 750 ML	79	2400	DEO SPRAY WHITE MUSK 300 ML	96
1887	DEINK 5 LT	79	2401	DEO SPRAY GOLD ARGAN 300 ML	96
1910-S	ULTRAKAL 750 ML	67	2402	DEO SPRAY BERGAMOT & JASMINE 300 ML	97
1913-S	SANI CITRIC 1 LT	67	2403	DEO SPRAY FLOWER BOUQUET 300 ML	97
1920-S	IGIENIKAL ORCHID 750 ML	66	2404	DEO SPRAY PEACH & GREEN APPLE 300 ML	97
1930-S	IGIENIKAL BALSAMIC 750 ML	66	2410	BIO BACT 5 LT	72
1931	IGIENIKAL BALSAMIC 5 LT	66	2430	BIO URISCREEN	73
1943	DEO WC GEL 700 ML	71	2431	URI DEO MANGO	73
1944	CHLOR WC GEL 700 ML	71	2432	URI DEO MINT	73
1945	WC GEL GREEN POWER 700 ML	70 - 163	2607	DICHLOR 56% 25 KG	154
1946	BLU POWER WC GEL	71	2609	ALGHICIDA 5 LT	155
1950	DEKAL 5 LT	30	2613	DICHLOR 56% 5 KG	154
1960-S	FORNONET 750 ML	40	2615	PH+ 15 LT	155
1961	FORNONET 5 LT	40	2616	FLOCCULANT 15 LT	155
1965	OVEN POWER 5 LT	41	2617	PH- 15 LT	156
1967	BRILL OVEN 5 LT	41	2618	ANTI CHLOR 5 LT	154
1976	RUDEAL 5 LT	156	3101	ULTRA DEGREASER GREEN POWER 750 ML	36 - 74 - 162
1980	UNBLOCKER GEL 1 LT	72	3102	CRYSTAL GREEN POWER 750 ML	74 - 164
2018	CREAM SOAP GOLD ARGAN 5 LT	124	3103	IGIENIKAL GREEN POWER 750 ML	66 - 163
2023	WASHDET EXTRA 5 LT	115	3104	NEOPOL GREEN POWER 5 LT	31 - 161
2025	WASHDET WHITE MUSK 5 LT	114	3105	SURFACE GREEN POWER 5 LT	51 - 163
2030	WOOLDDET 5 LT	115	3106	NEOPOL GREEN POWER 1 LT	31 - 161
2034	WASHDET BLUE ORCHID 5 LT	115	3109-S	SURFACE GREEN POWER 1 LT	51 - 163
2038	WASHDET BLUE ORCHID 15 LT	115	3110	SOFTDET GREEN POWER 5 LT	116
2046	LAUNDRY NEUTRALIZER 15 LT	111	3112	WASHDET GREEN POWER 5 LT	114 - 165
2049HC	QUANTUM OXYGEN 15 LT	108 - 165	3113	DEKAL GREEN POWER 5 LT	30 - 162
2050HC	QUANTUM OXYGEN 5 LT	108 - 165	3210	TOTAL BODY 500 ML	130
2051HC	QUANTUM BASIC 5 LT	107 - 164	3211	TOTAL BODY SOFT MOUSSE 600 ML	130
2052HC	QUANTUM SURF 5 LT	107 - 164	4005	MOUSSE SOAP GREEN POWER 600 ML	123 - 166
2053HC	QUANTUM CHLOR 5L	108	4006	LIQUID SOAP GREEN POWER 5 LT	123 - 166
2054HC	QUANTUM PERACETIC 5 LT	109	4012	TRILOGY WASH T1 5 LT	28
2060	SOFTDET WHITE MUSK 5 LT	116	4013	TRILOGY BOOST T2 5 LT	28
2064HC	QUANTUM SOFT MEDITERRANEAN FLOWERS 5 LT	110 - 165	4014	TRILOGY RINSE T3 5 LT	28
2065HC	QUANTUM SOFT ECO 5 LT	109	4015	LIQUID SOAP GREEN POWER 1 LT	123 - 166
2071	LAUNDRY SOFT MEDITERRANEAN FLOWERS 15 LT	110	4017	STOVIL GREEN POWER 5 L	21 - 161
2071HC	QUANTUM SOFT MEDITERRANEAN FLOWERS 15 LT	110 - 165	4018	STOVIL GREEN POWER 15 L	21 - 161
2072	LAUNDRY SOFT WHITE MUSK 15 LT	111	4019	BRILL GREEN POWER 5 LT	24 - 161
2073HC	QUANTUM PERACETIC 15 LT	109	4020	BRILL GREEN POWER 15 LT	24 - 161
2076	LAUNDRY SURF 15 LT	108	6010	WASH CREAM 600 ML	132
2076HC	QUANTUM SURF 15 LT	107 - 164	6011	SOFT EMULSION 600 ML	132
2077	LAUNDRY BASIC 15 LT	107	6012	SOFT SHOWER GEL 600 ML	130
2077HC	QUANTUM BASIC 15 LT	107 - 164	6013	SOFT SHAMPOO 600 ML	131
2078HC	QUANTUM CHLOR 15 LT	108	6014	INTIMATE WASH 250 ML	131
2082	LIQUID CHLOR 15 LT	154	6020	BARRIER CREAM 150 ML	133
2083HC	QUANTUM SOFT ARGAN 5 LT	110	6030	TOTAL BODY 1 LT	130
2086	ATOMIC ULTRA 12 KG	117	6031	CLEANSING OIL 300 ML	131
2087	ATOMIC POWER 12 KG	117	6033	PRECIOUS OIL 300 ML	132
2090HC	QUANTUM BOOSTER 5 LT	109	7001	PETRA 24 15 LT	140
2091	SOFTDET BLUE ORCHID 5 LT	117	7002	POWER XP 5 LT	140
2092	SOFTDET BLUE ORCHID 15 LT	117	7003	METAL BRO 5 LT	141
2100	NATURAL 5 LT	43	7004	GRAFFITI RM 5 LT	141
2122	ACTIVE CHLOR TABLET	38 - 56 - 70	7005	AQUA 5 LT	143
2131	FRYDET TABLET 500 G	39	7006	HYDRO S 5 LT	144
2142	EMULSI CIP 15 LT	148	7007	ACID SP 5 LT	142
2150	URI TABS 3 KG	72	7008	AQUA PLUS 5 LT	143
2161	CAFFE' WASH 800 ML	41	11847	TANK HOLDER BRACKET	29 - 112
2200	DEO SURFACE WHITE MUSK 5 LT	50 - 92	12388	DISPENSER FOR TANK 5 LT	129 - 150
2201	DEO SURFACE GOLD ARGAN 5 LT	50 - 92	SN2026	WASHDET ROSE PETALS 5 LT	114
2202	DEO SURFACE FRESH CITRUS 5 LT	51 - 93	SN2062	SOFTDET ROSE PETALS 5 LT	116

# Icons



1



2



3



4



5



6



7



8



9



10



11



12



13



14



15



16



17



18



19



20



21



22



23



24



25



26



27



28



29



30



31



32



33



34



35



36

- |  |                                      |                              |
|--|--------------------------------------|------------------------------|
| 1 Electronic dishwasher and washing machine dispensers | 13 Office equipment                  | 25 Extra fragrance           |
| 2 Mechanical dishwashing                               | 14 Dusting                           | 26 Eliminates odour          |
| 3 Rinse aid action                                     | 15 Floors and large surfaces         | 27 Hand washing              |
| 4 Cookware   | 16 MOP                               | 28 Washing machine           |
| 5 Hand dishwashing                                     | 17 Scrubber machines                 | 29 Sheets and fabrics        |
| 6 Food equipment and counters                          | 18 Injection and Extraction Machines | 30 ProCaps Technology        |
| 7 Kitchen  | 19 Carpets and rugs                  | 31 For sensitive skin        |
| 8 Oven and grill                                       | 20 Shower and bathroom fittings      | 32 Dermatologically tested   |
| 9 Deep fryers  | 21 Toilets and urinals               | 33 For fragile hair          |
| 10 Coffee machine                                      | 22 Silver                            | 34 Stubborn dirt             |
| 11 Food cleaning                                       | 23 Glass cleaning                    | 35 Without hazard pictograms |
| 12 Antibacterial                                       | 24 Perfume                           | 36 Ready to use              |

# Certifications



**1**



**2**



**3**



**4**



**5**

**1** Ecolabel certified product/system

**2** CAM certified product

**3** Medical Surgical Device

**4** Suitable for H.A.C.C.P. use

**5** NSF-certified product



Riviera Maestri del Lavoro, 10  
35127 - Padova (PD), Italia  
[info@italchimica.it](mailto:info@italchimica.it)

[italchimica.it](http://italchimica.it)



# **SANiTEC**

Professional cleaning solutions



**Help the environment,**  
use the Sanitec catalogue in digital format